

CARVART®

BY
SOEMA®

Handcrafted Technology

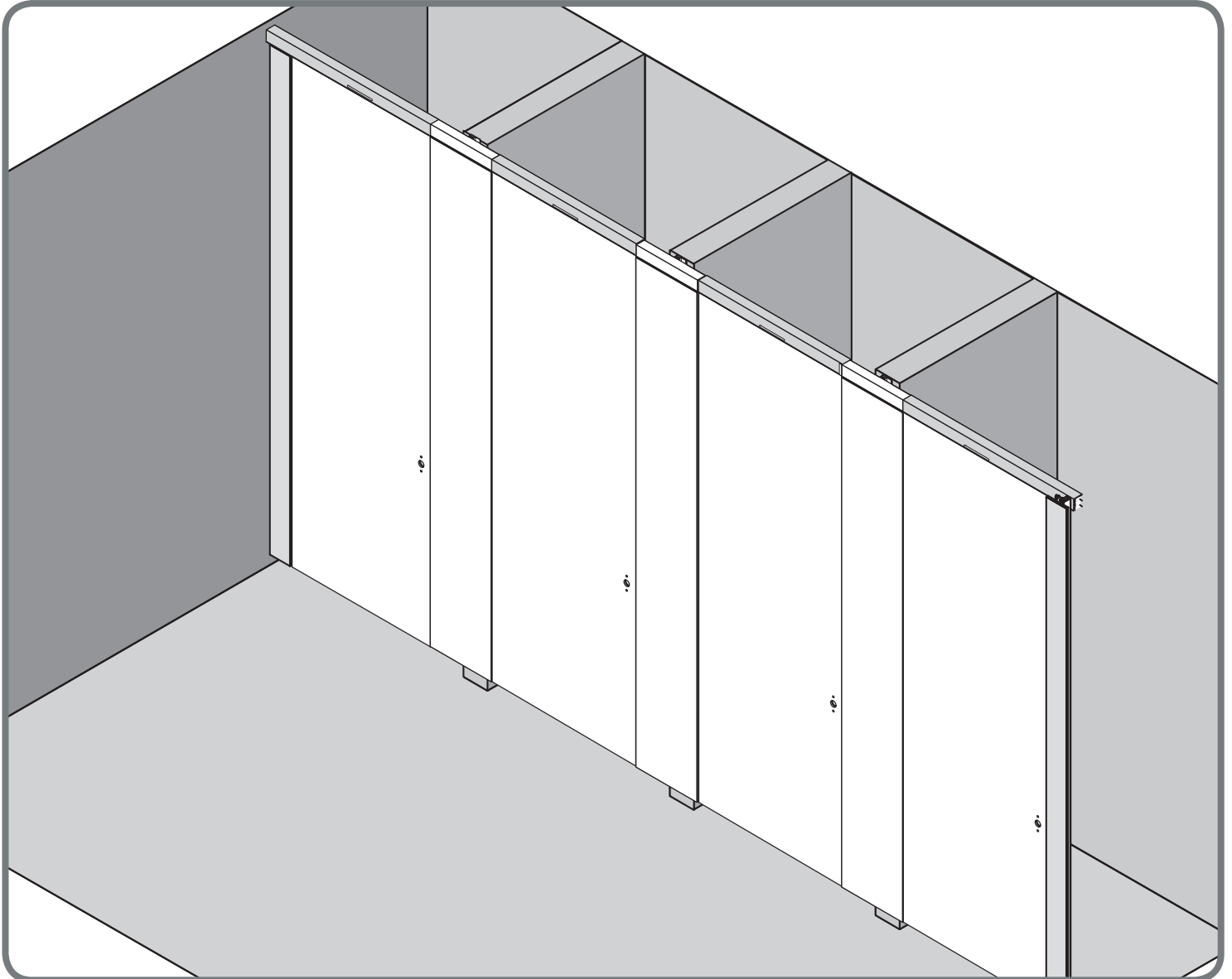
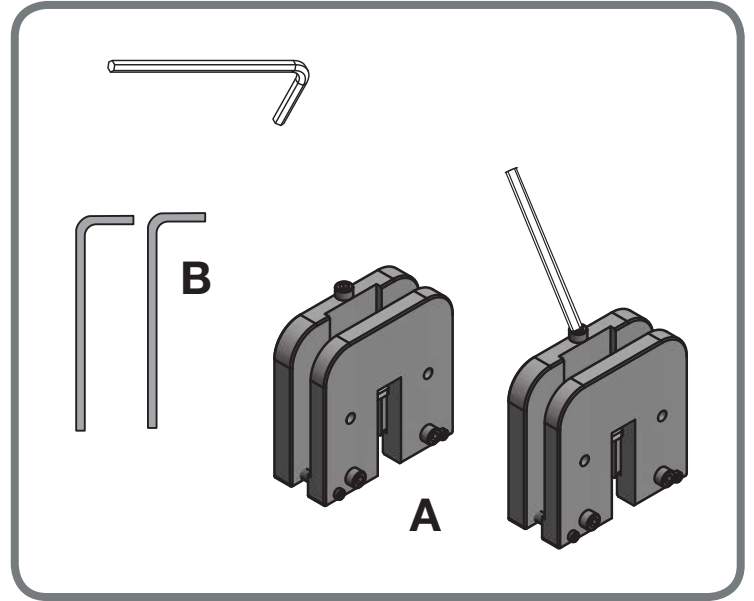
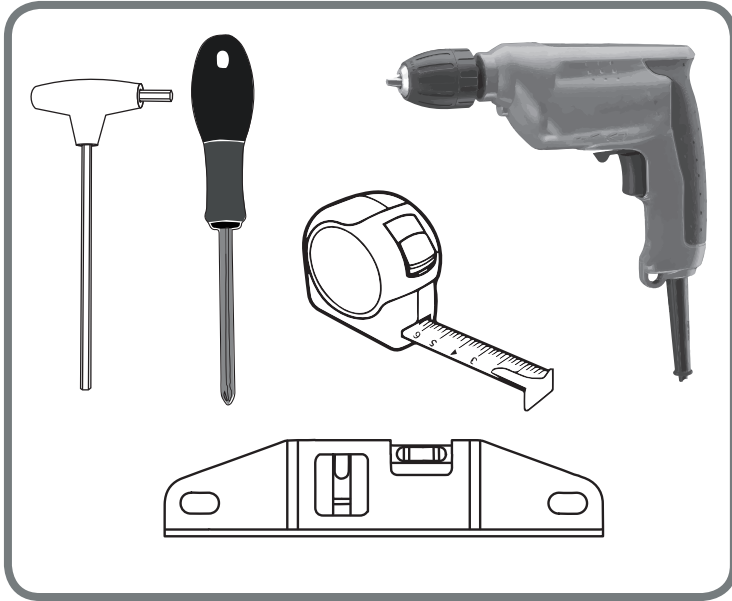

TOLERANCES

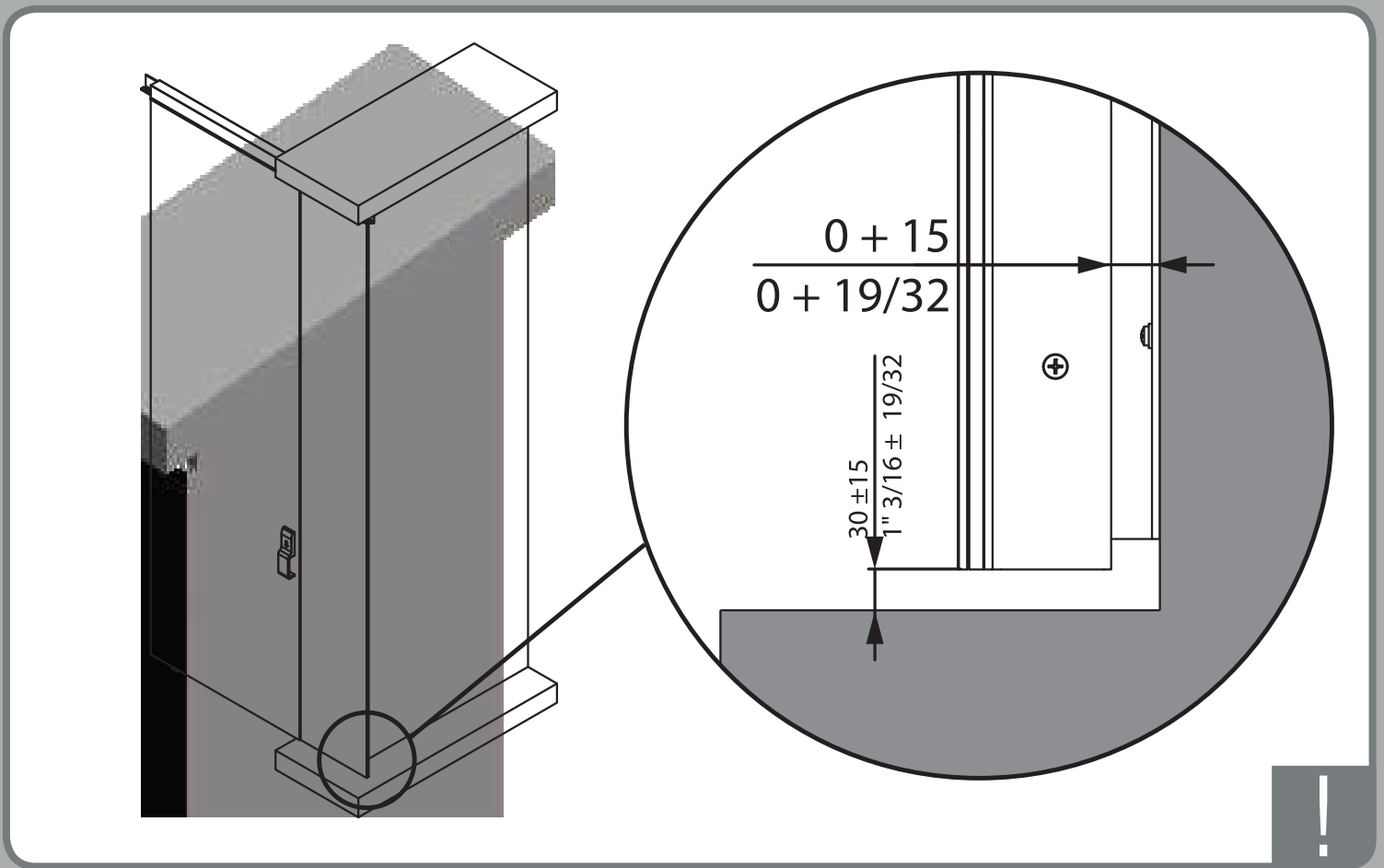
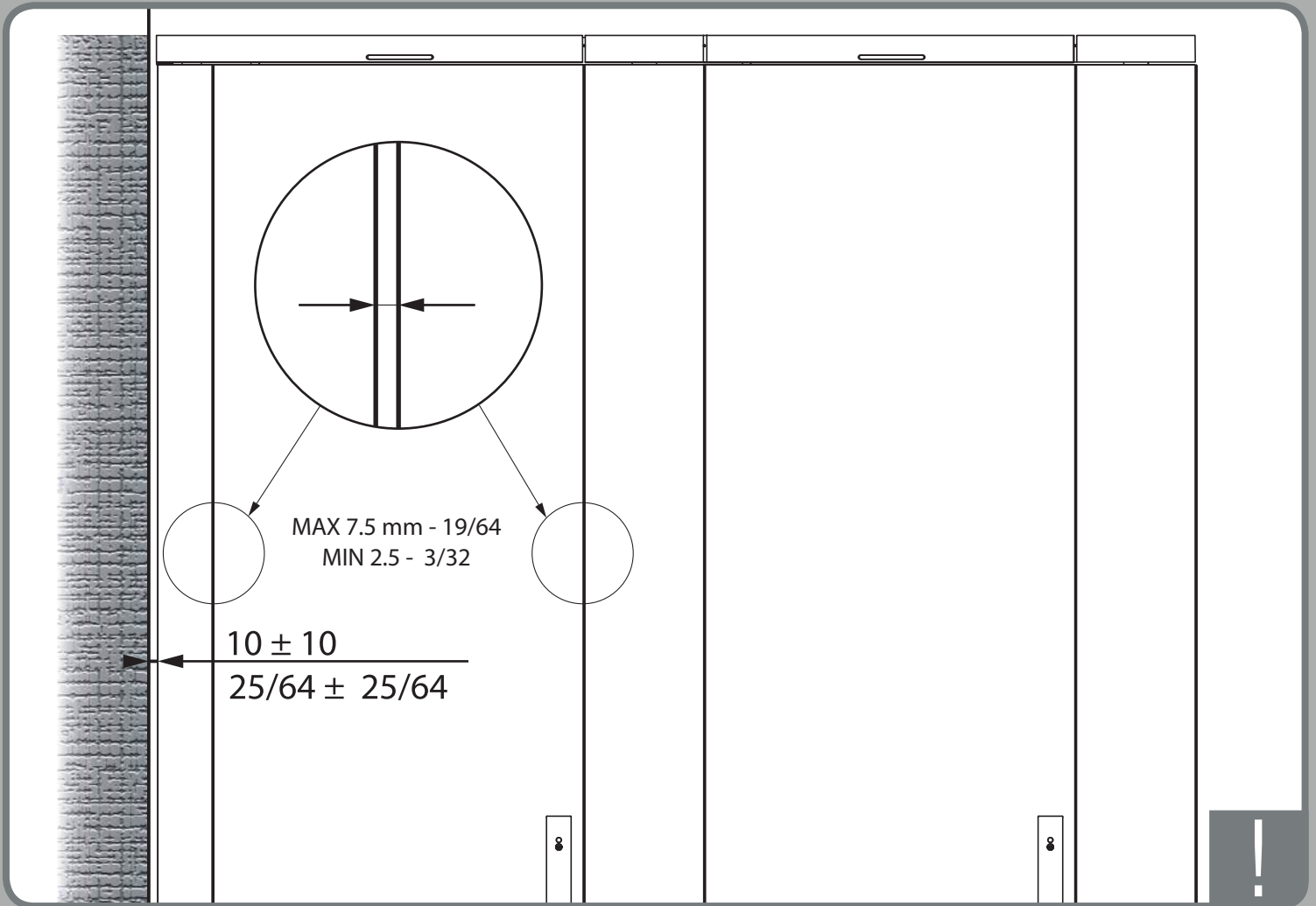

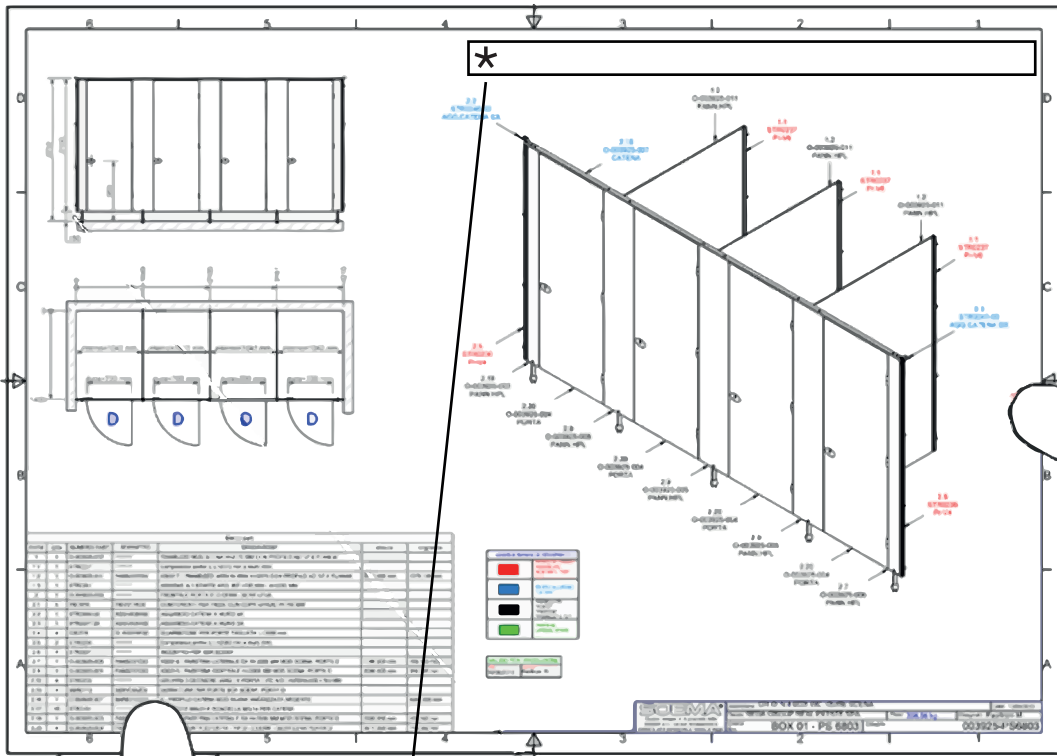

1

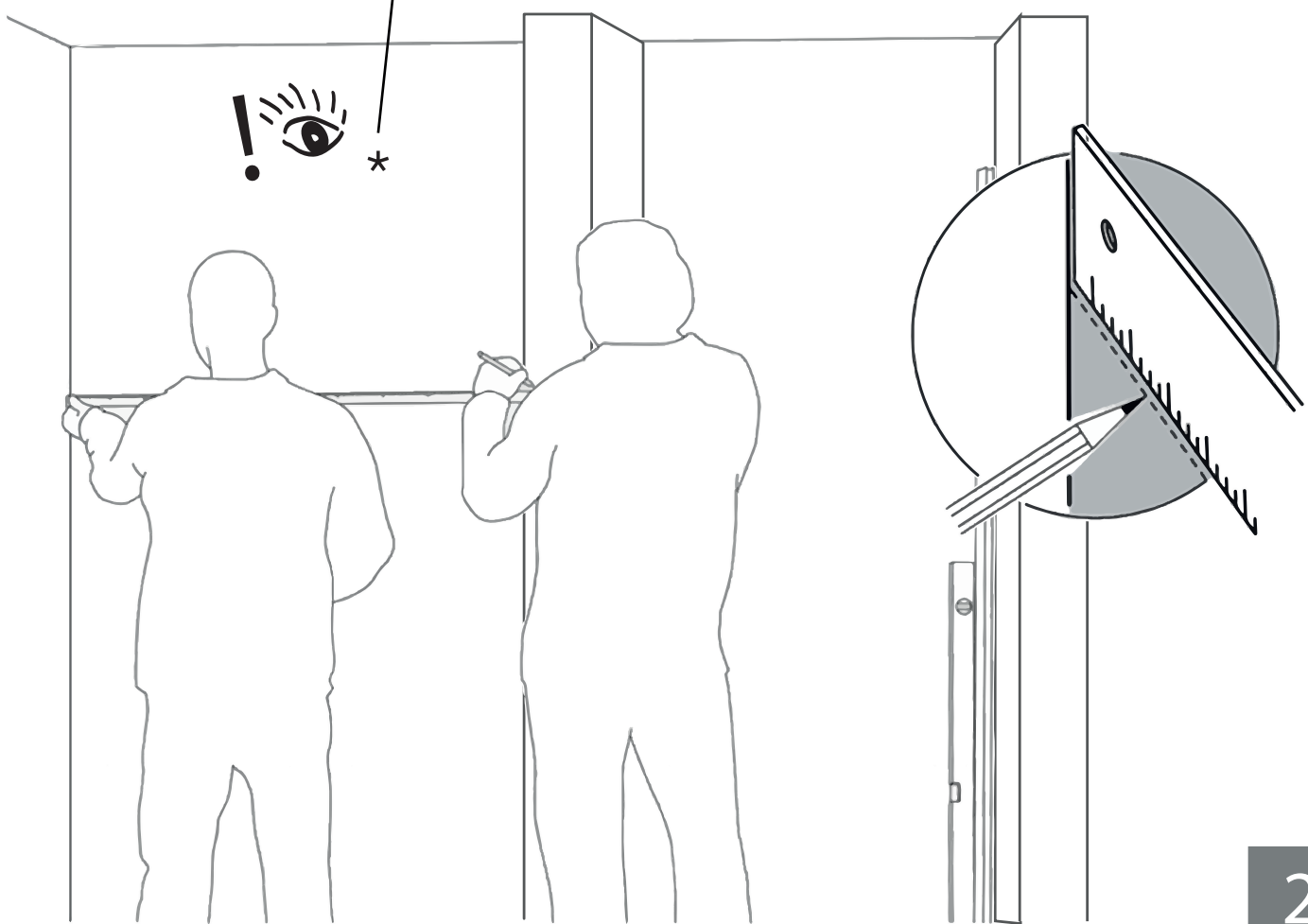

2

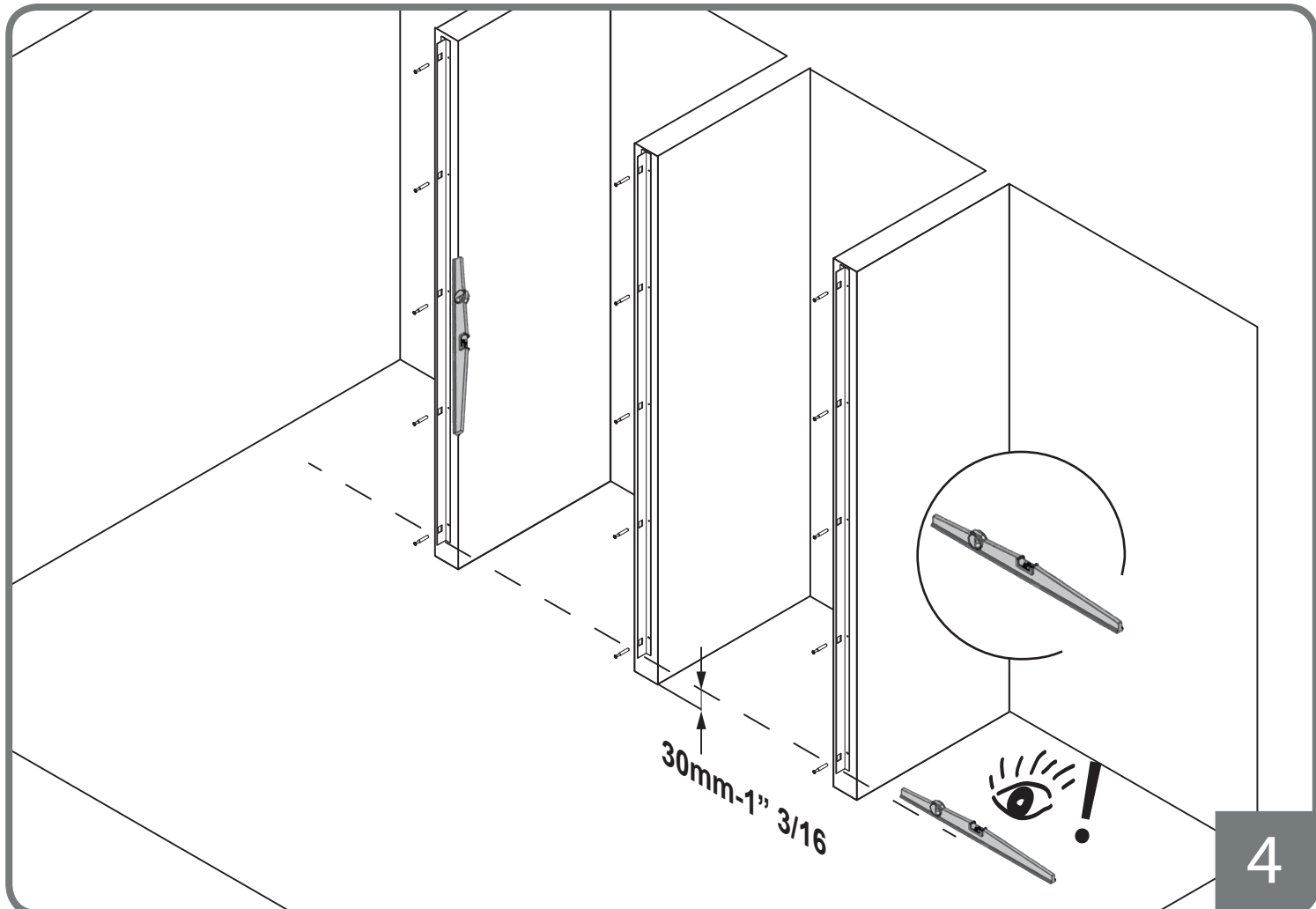
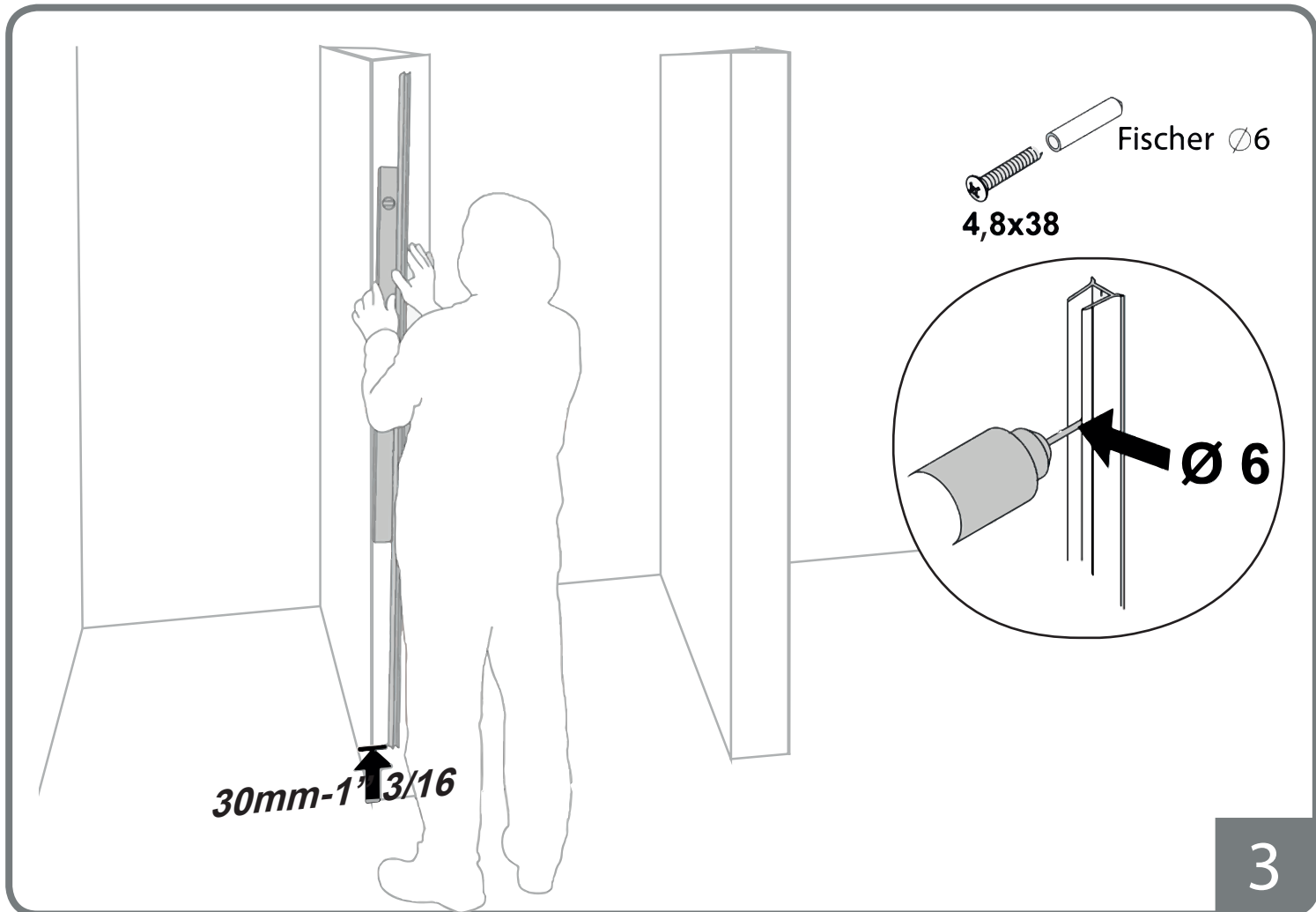

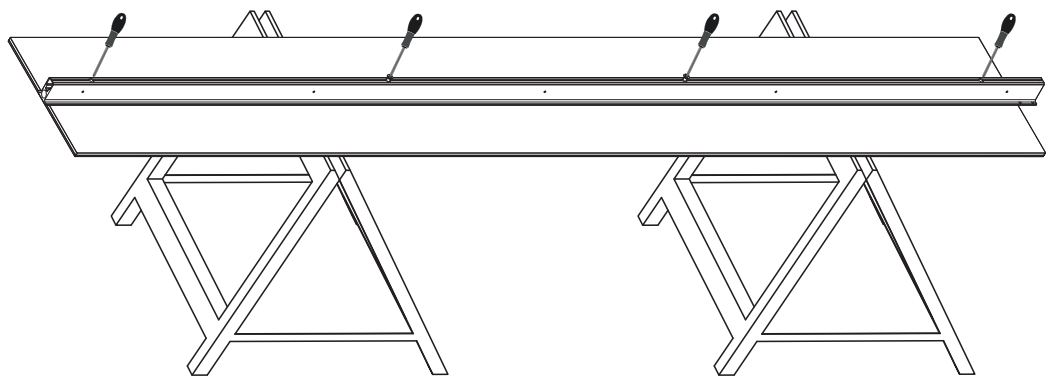
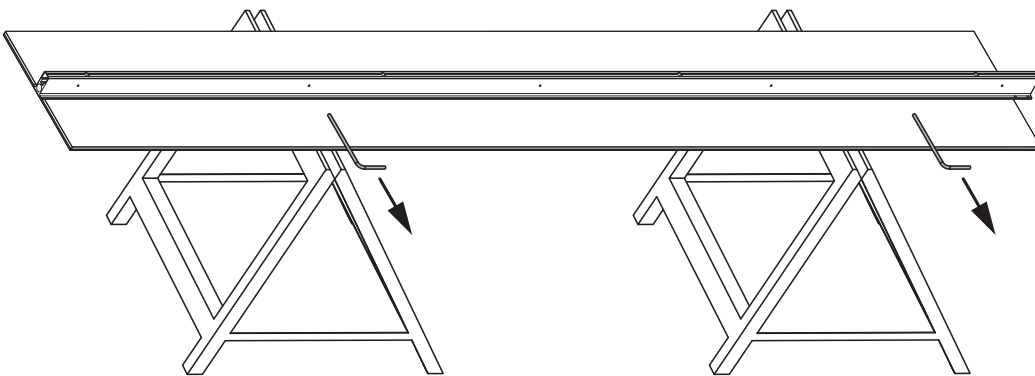
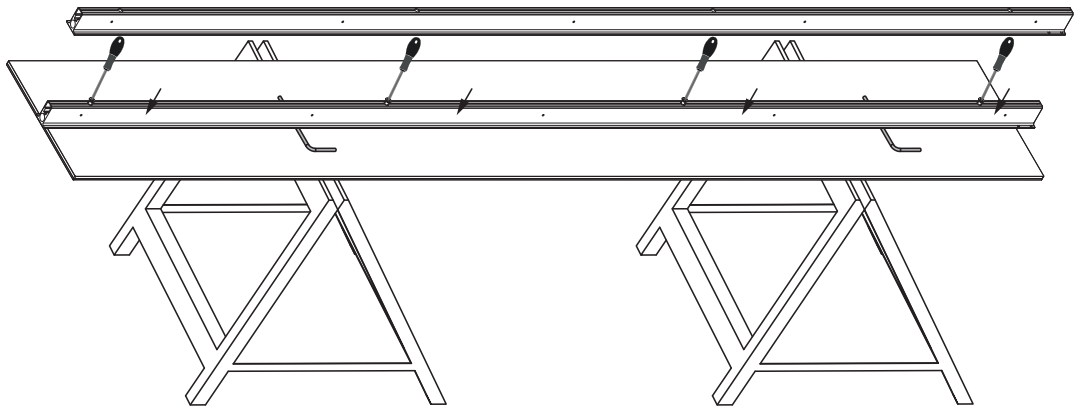
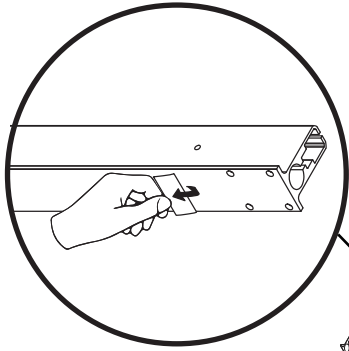
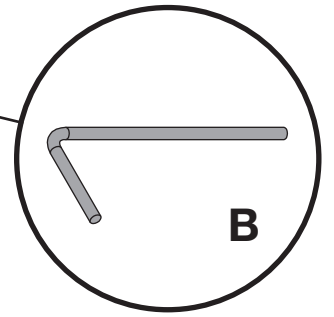
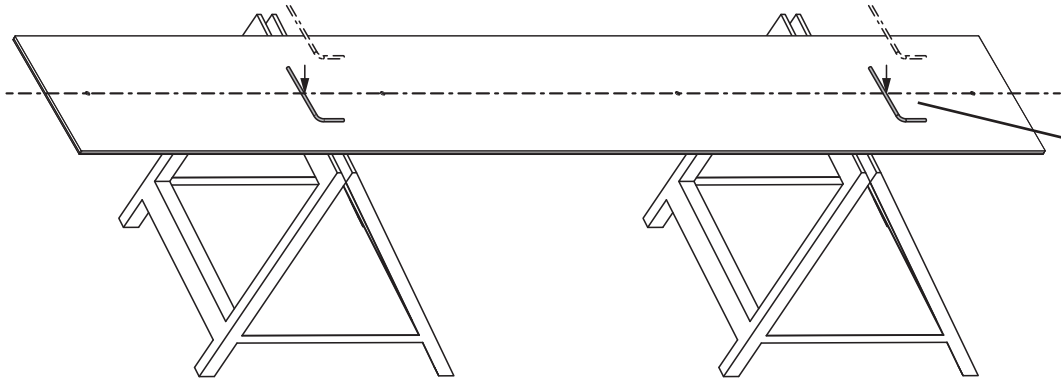

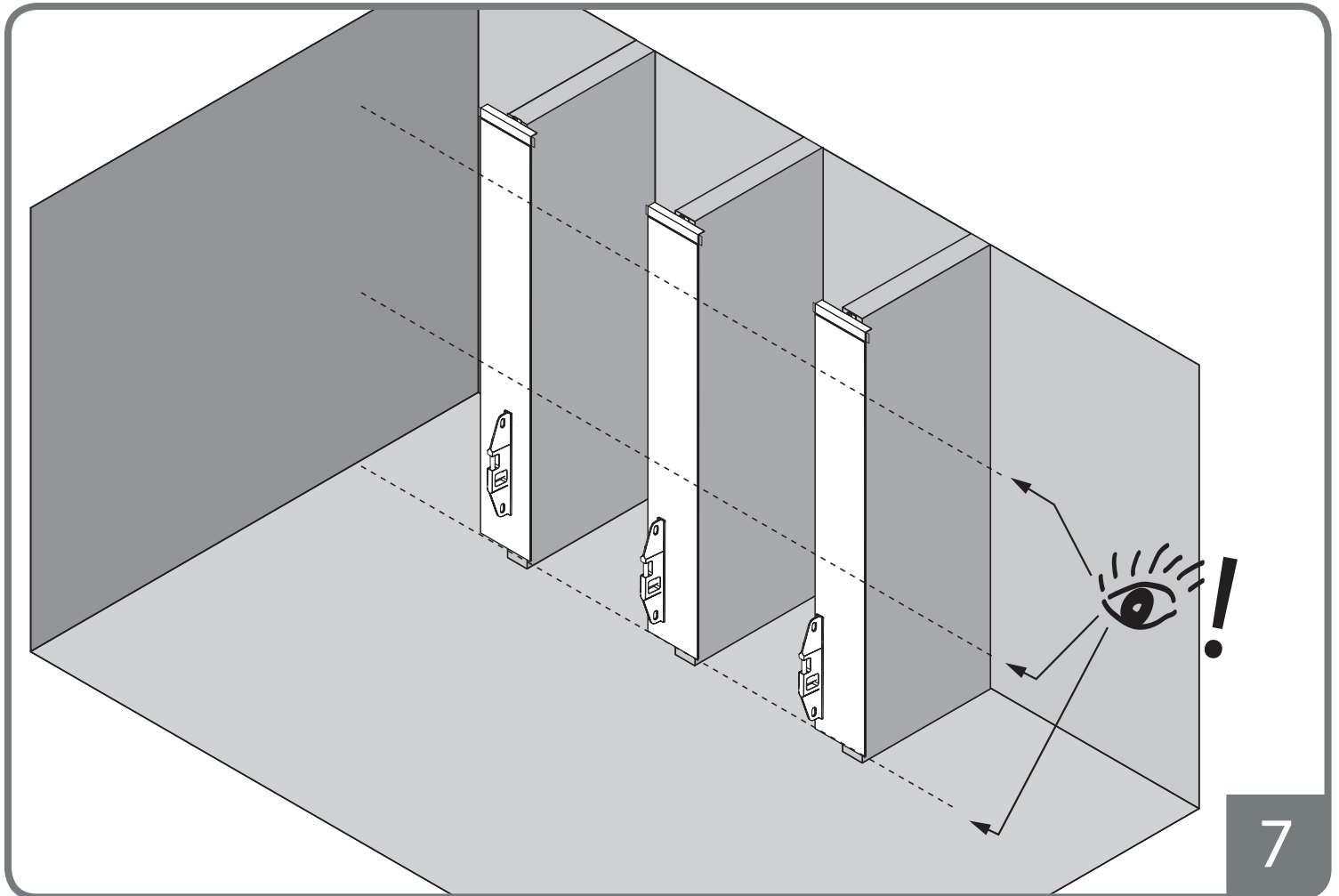
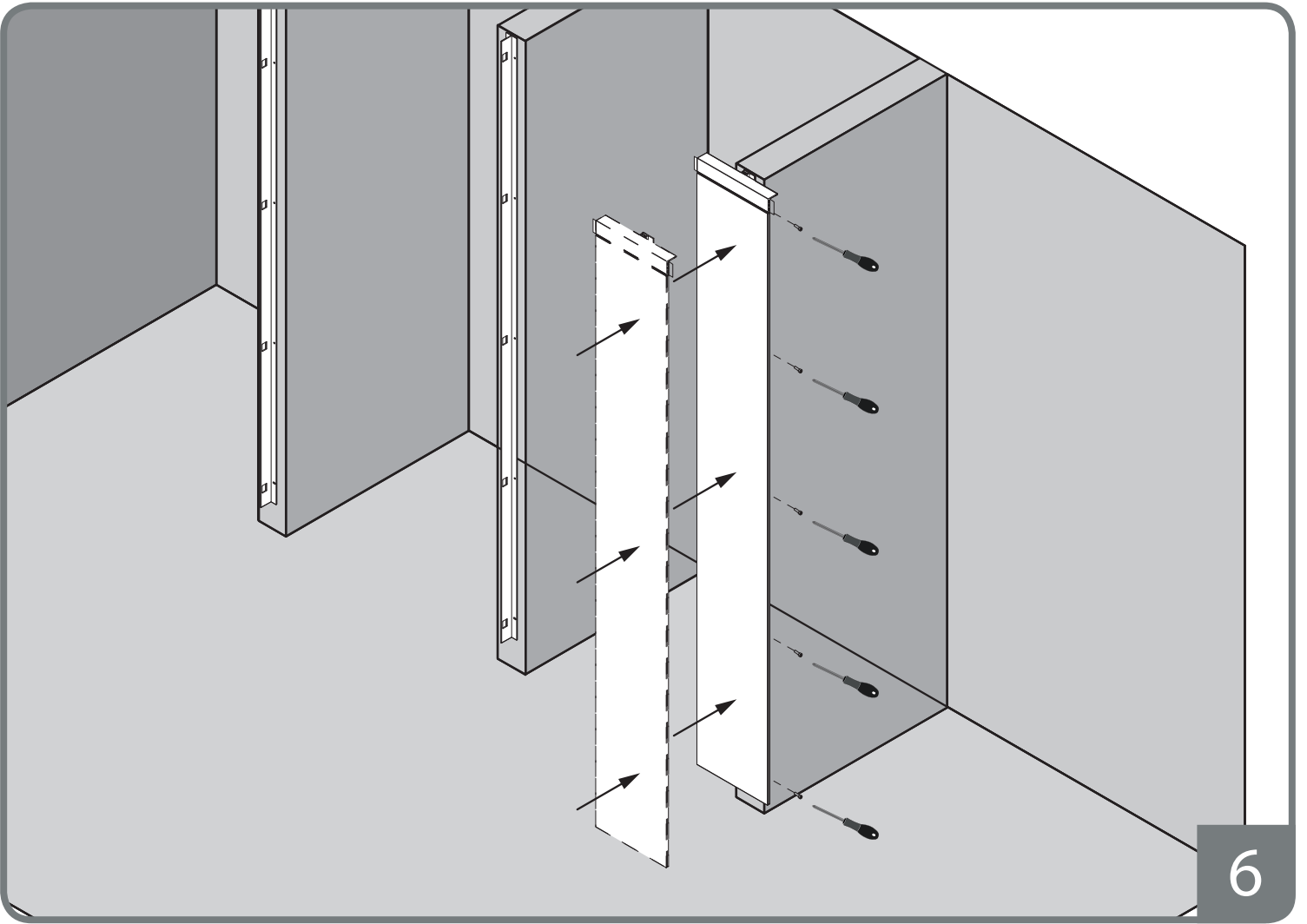

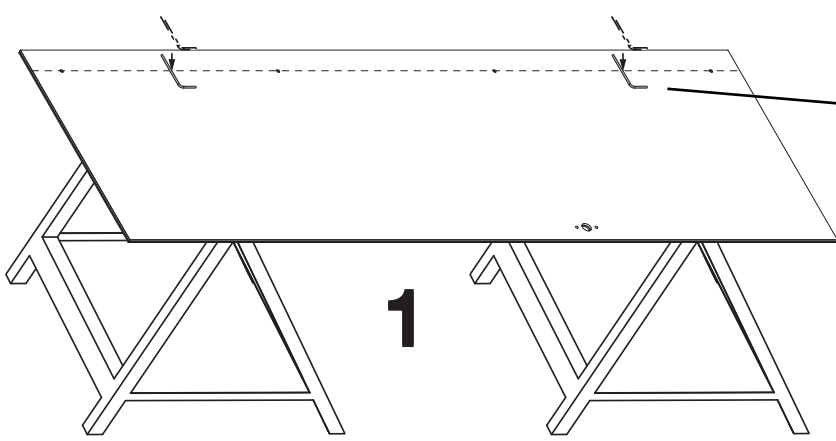

1

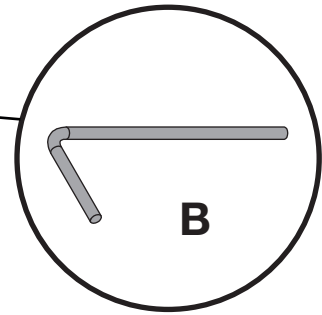

B



M6x35

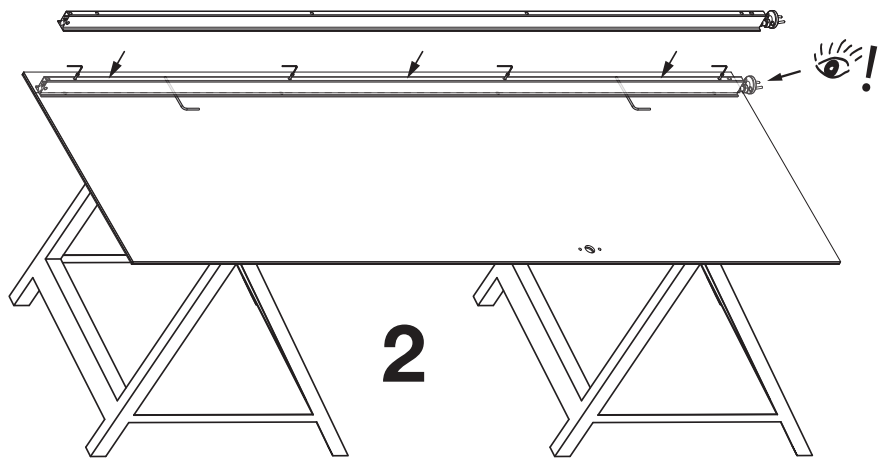
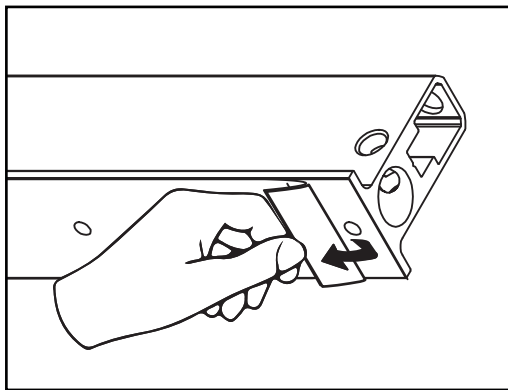

2

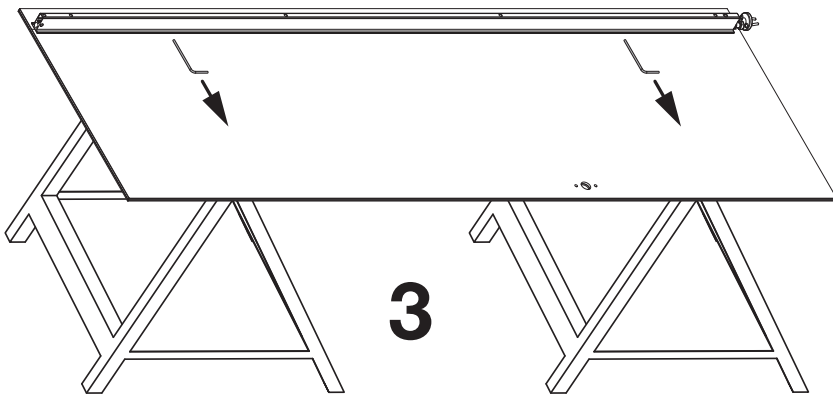

3

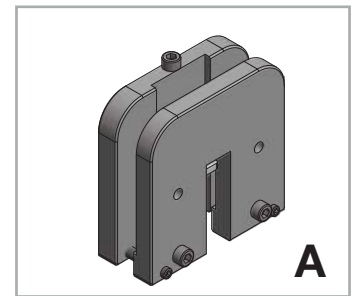

A

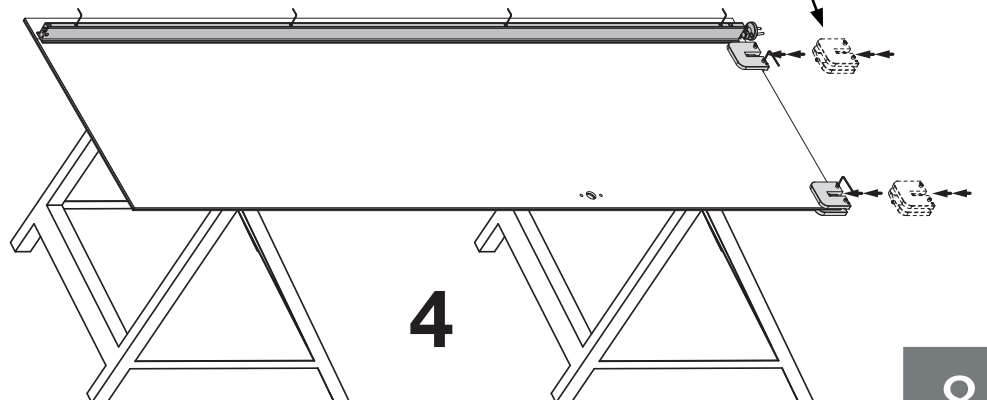

4

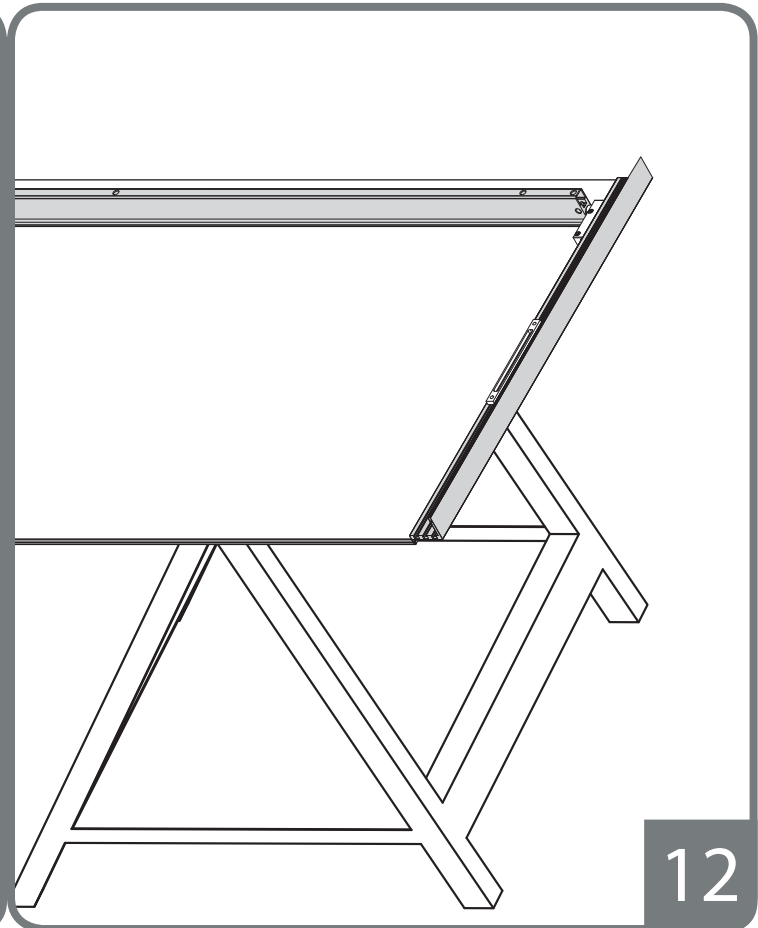
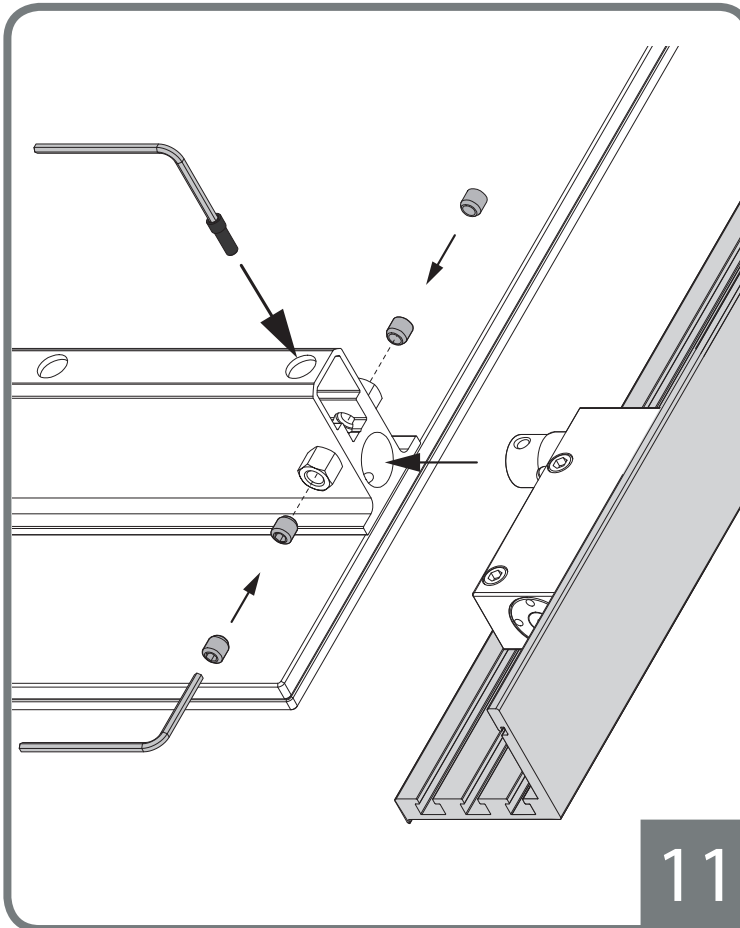
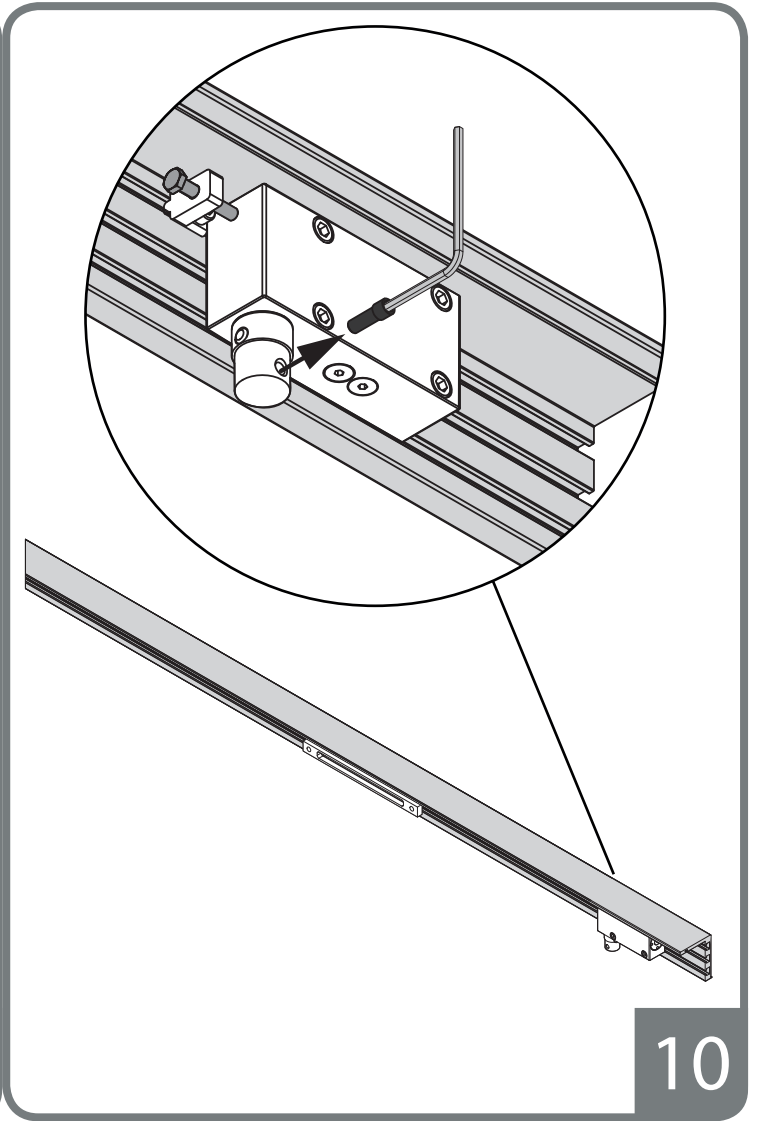
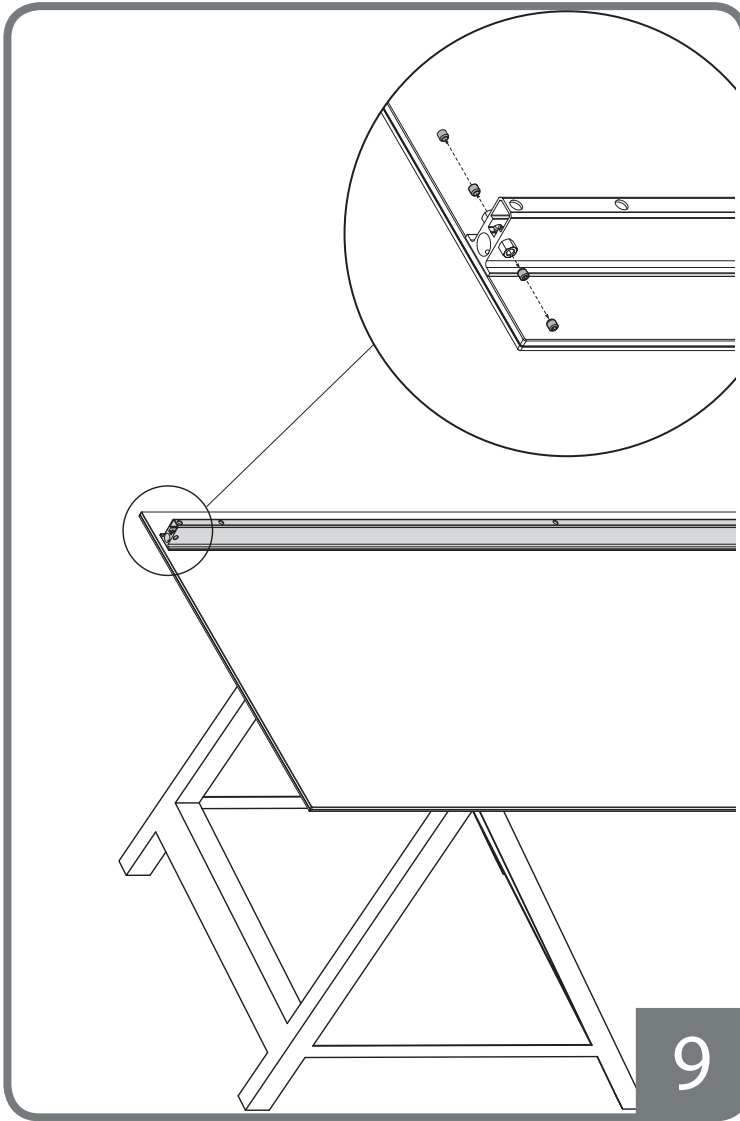

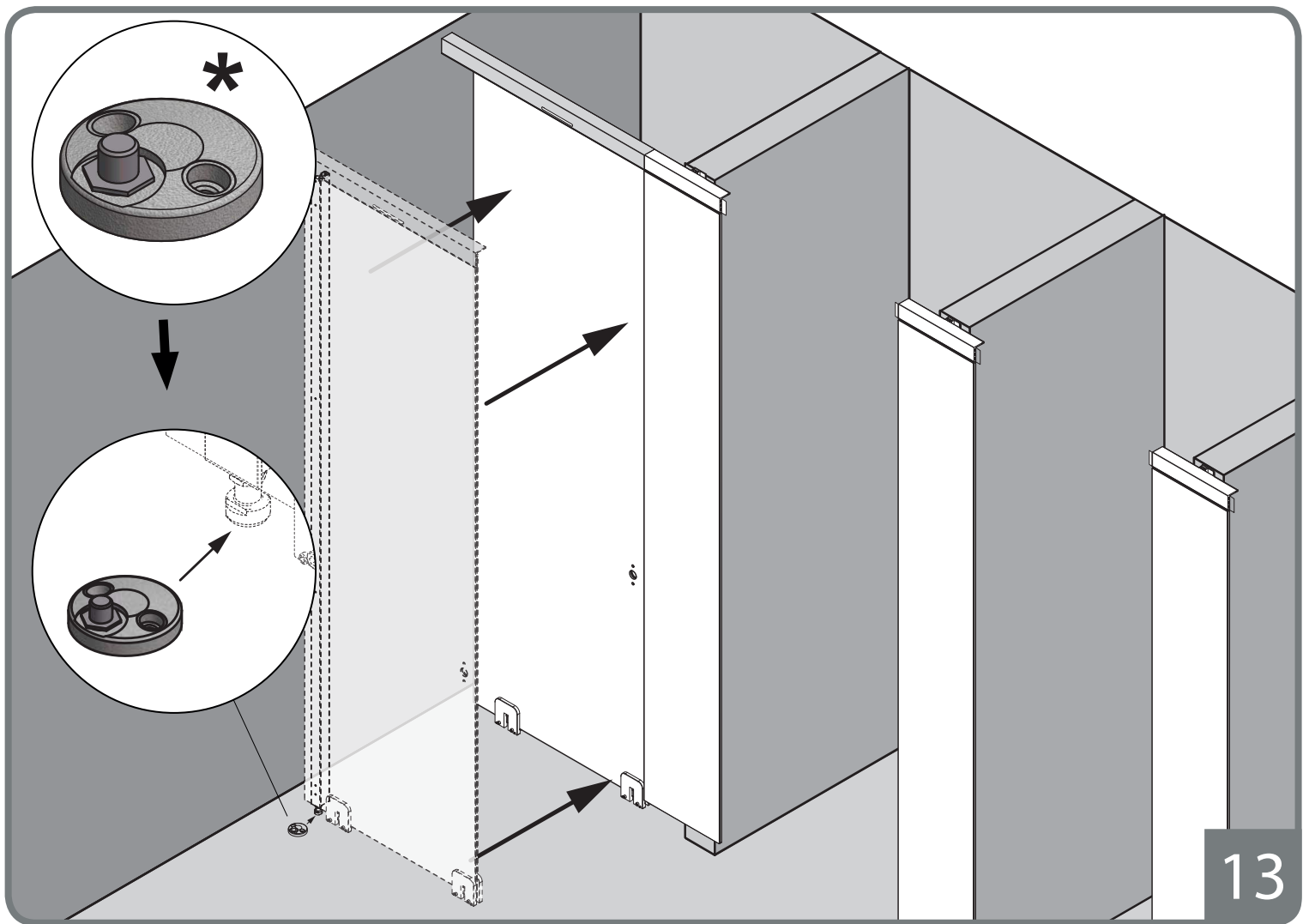

13

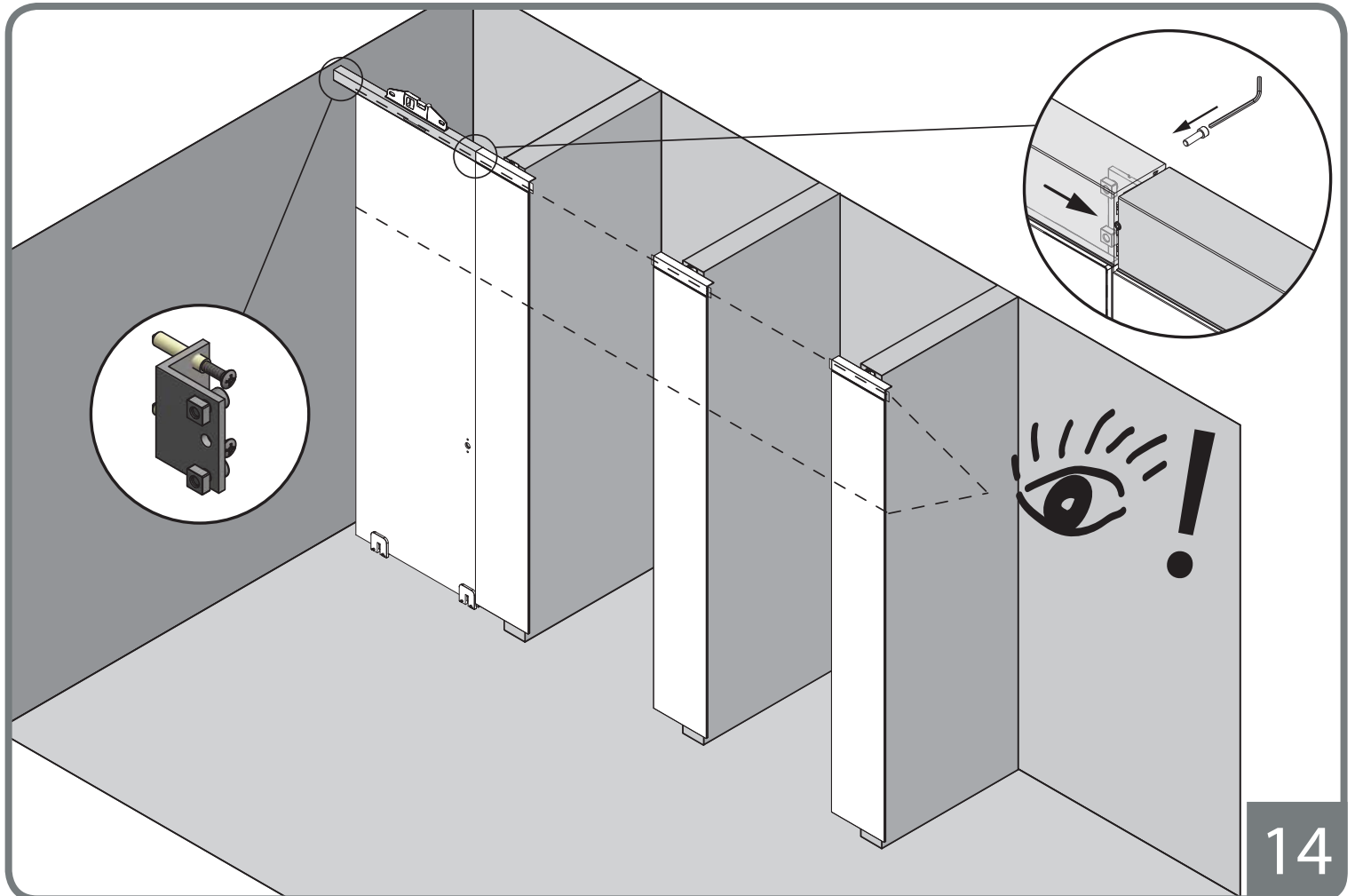

14

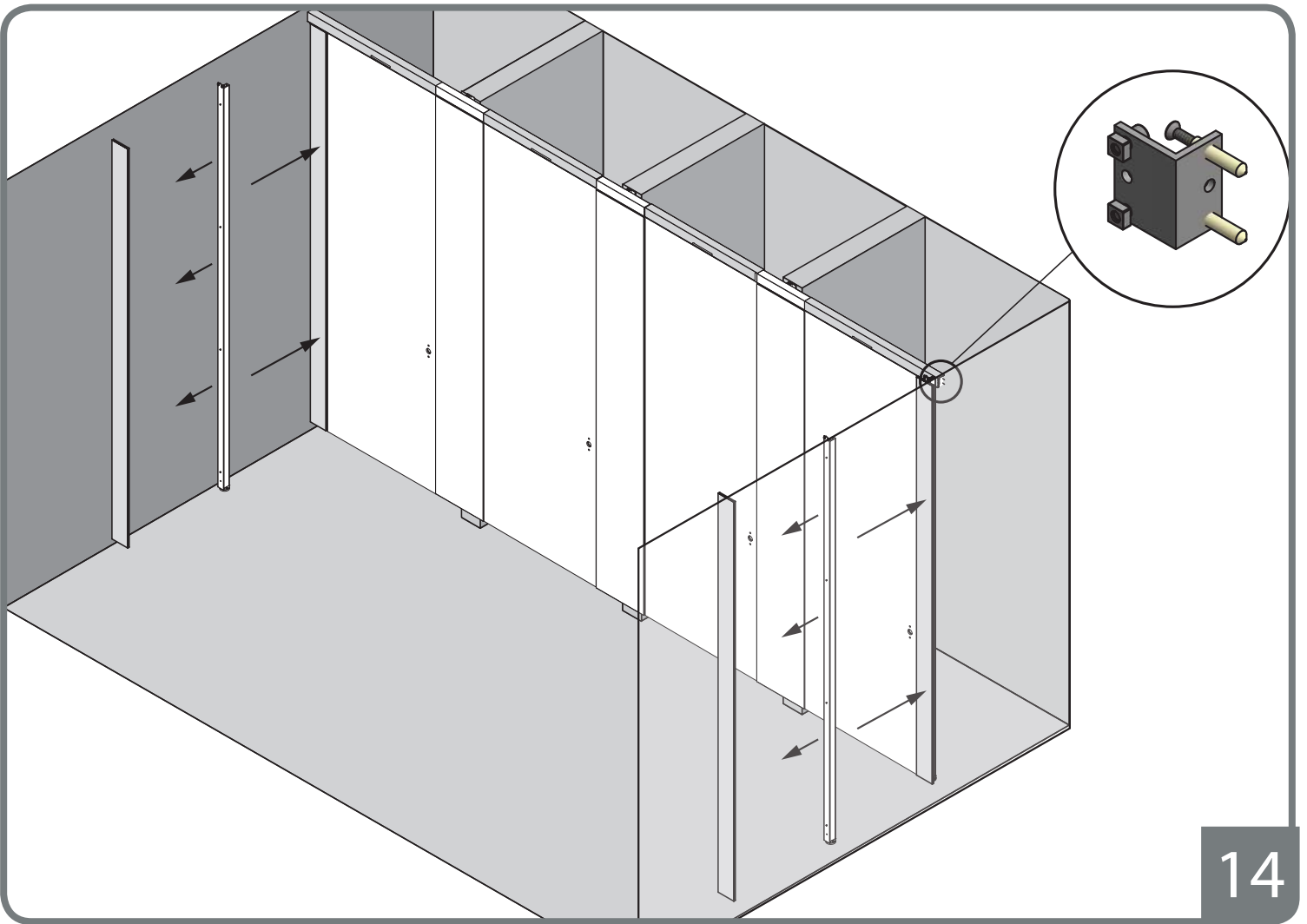

14

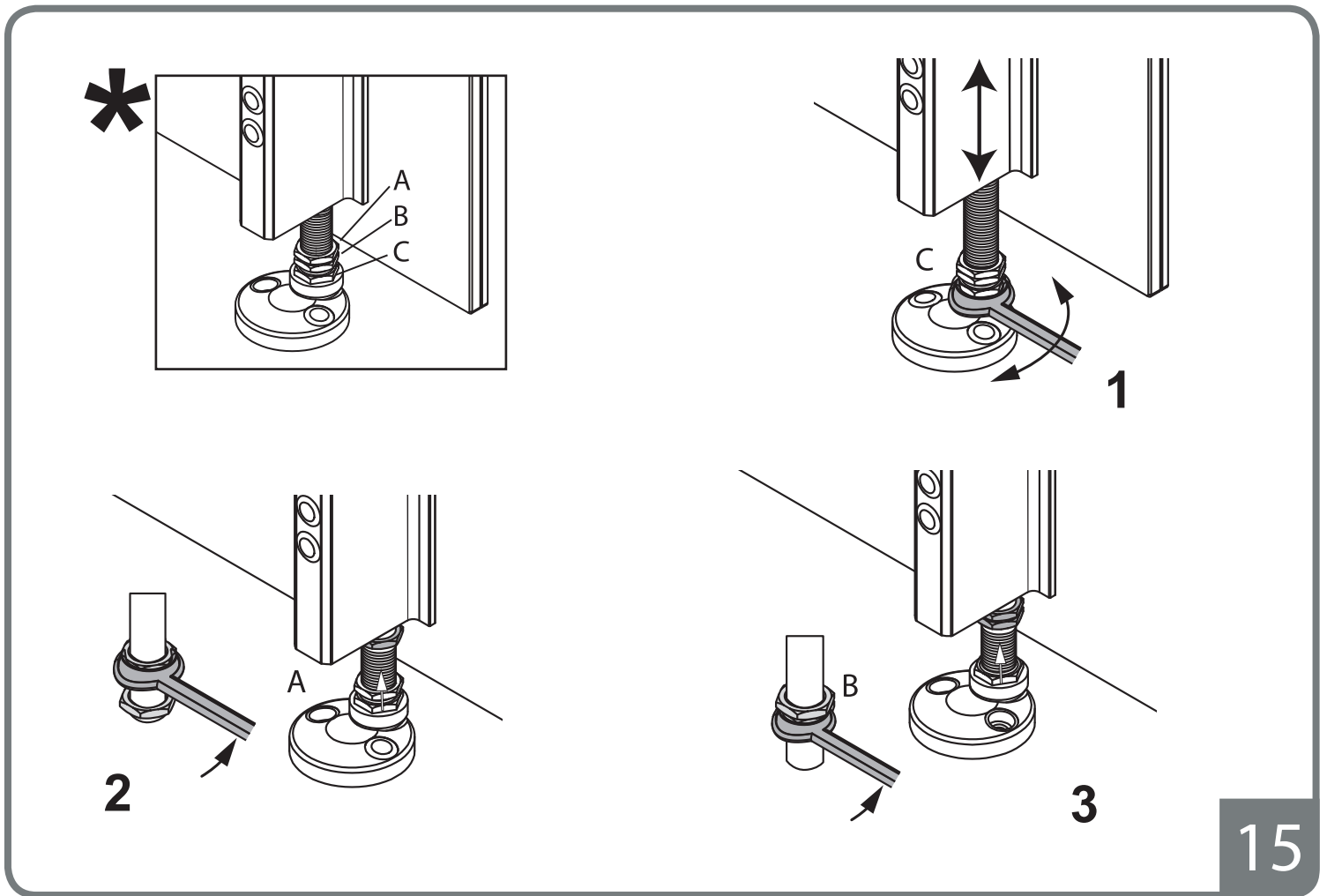

15

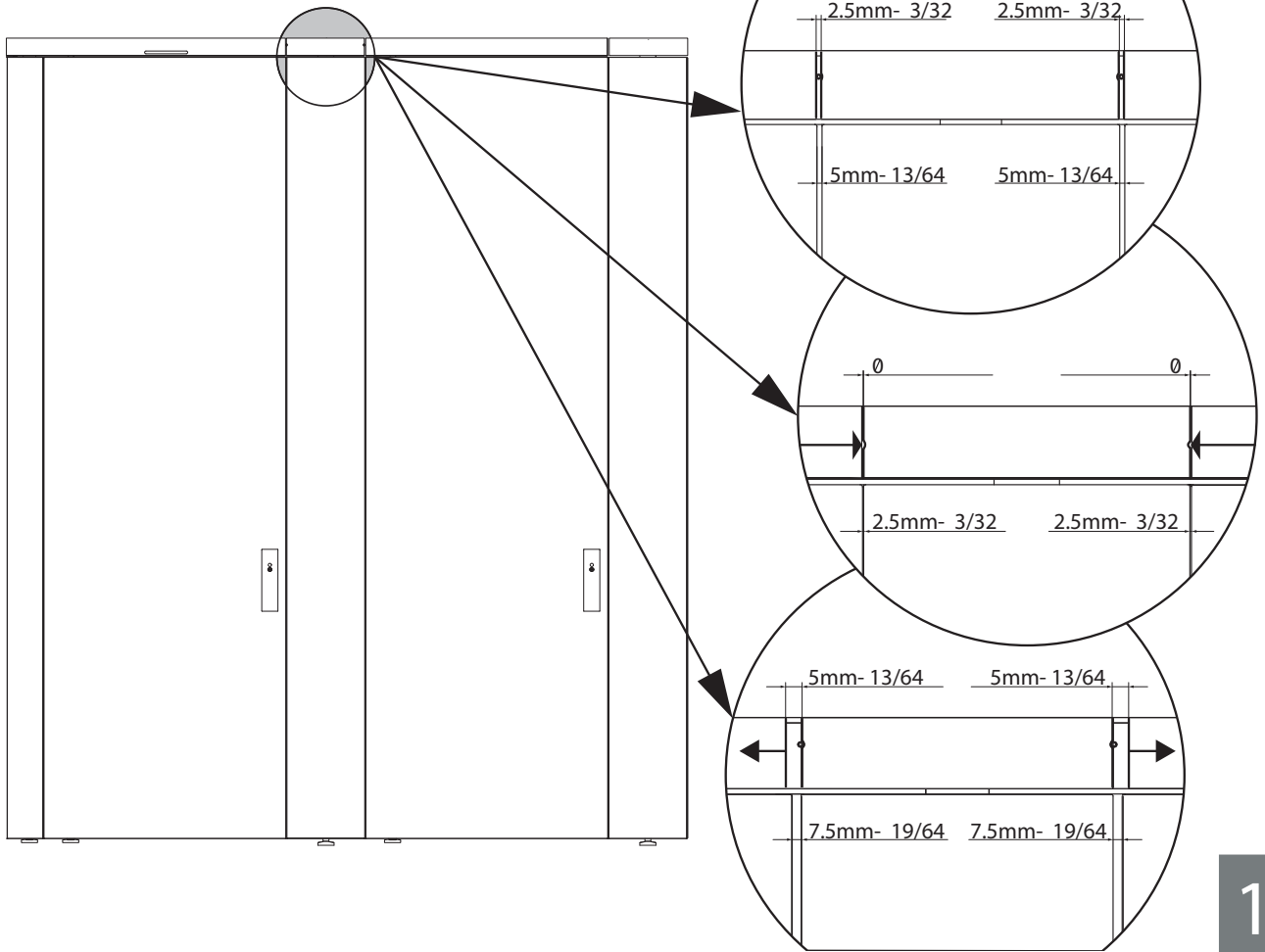

15

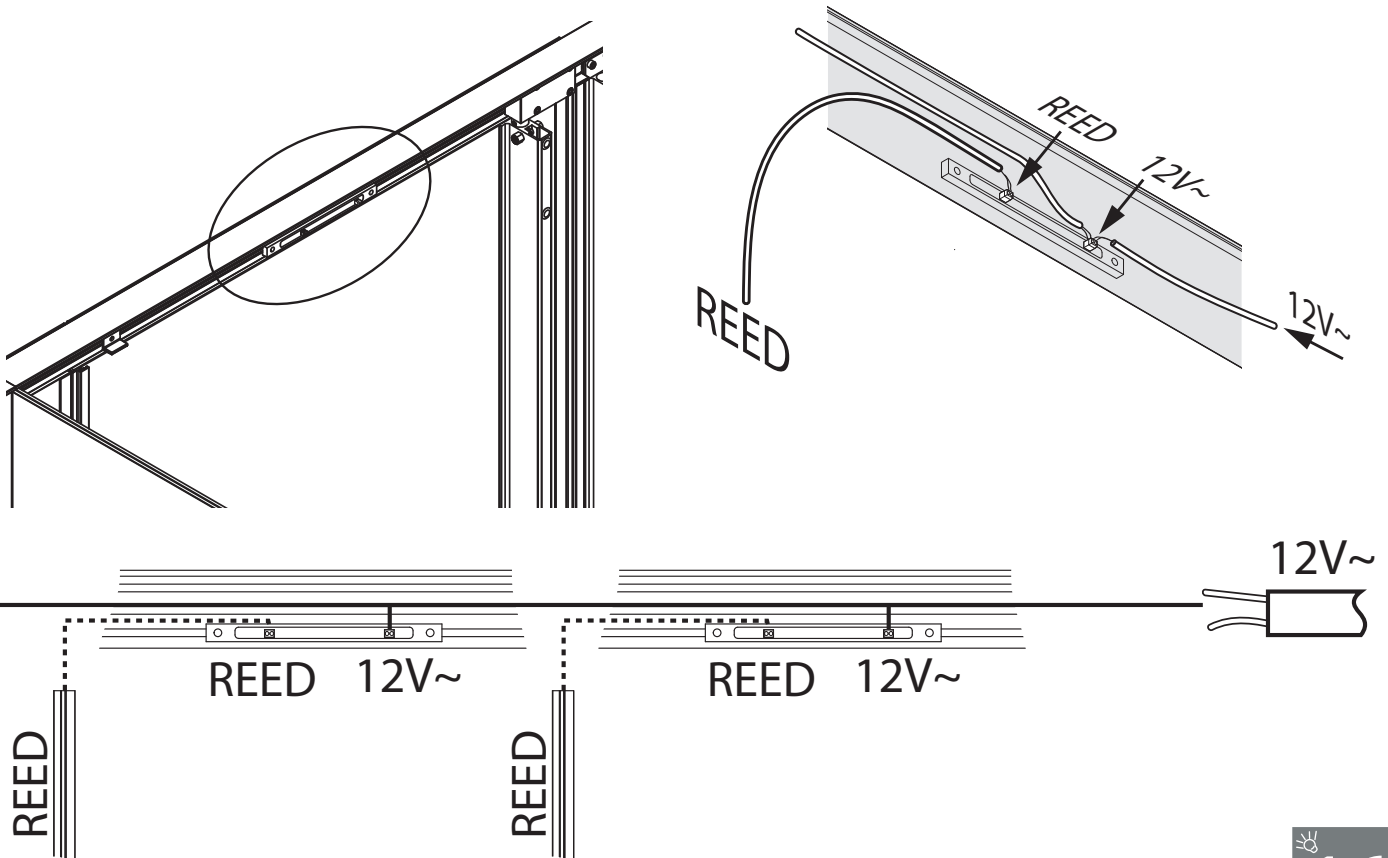

16

HINGE

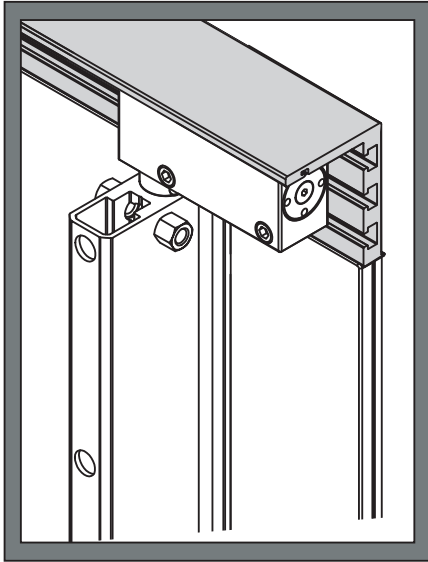

1

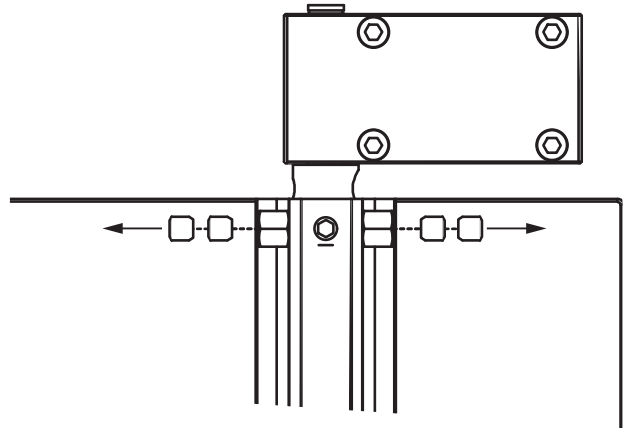

2

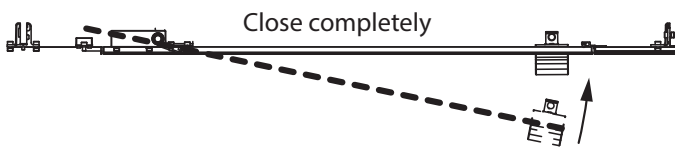

CLOSING SPEED REGULATION

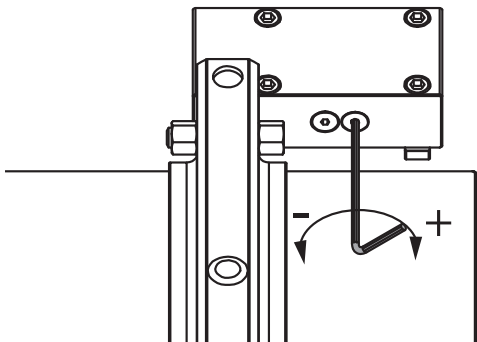

3

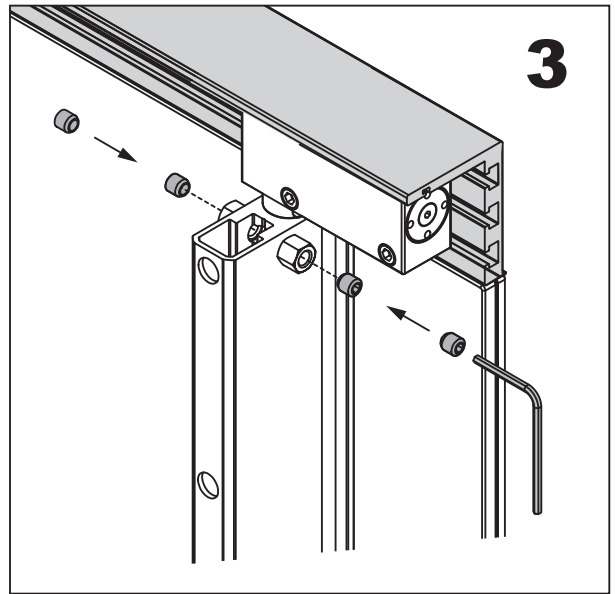

HINGE POSITION ADJUSTMENT

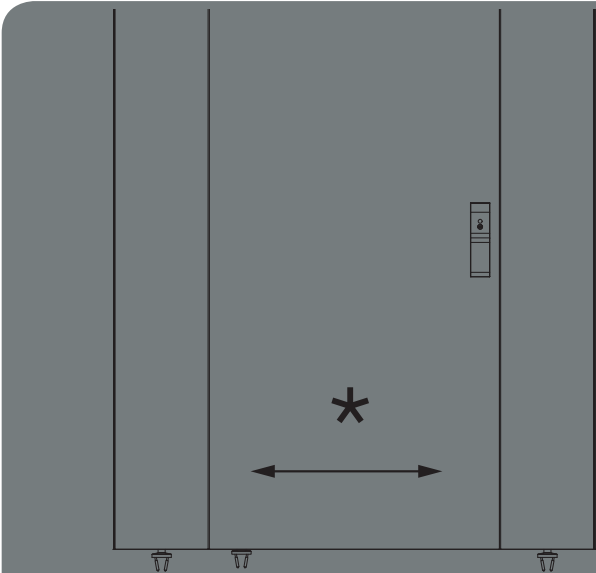
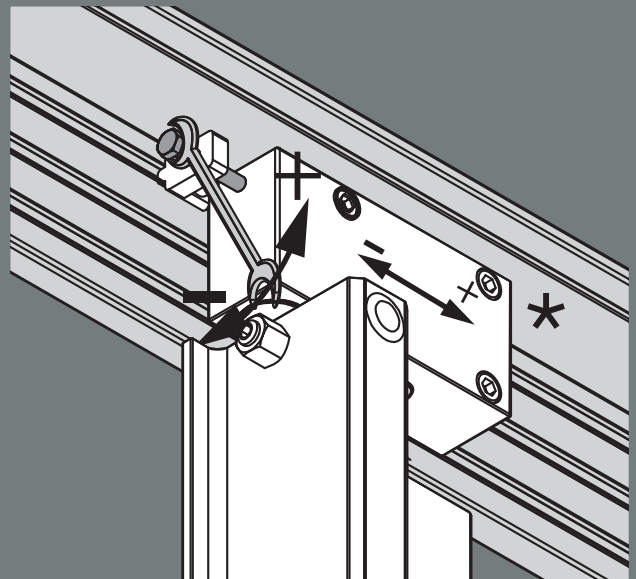

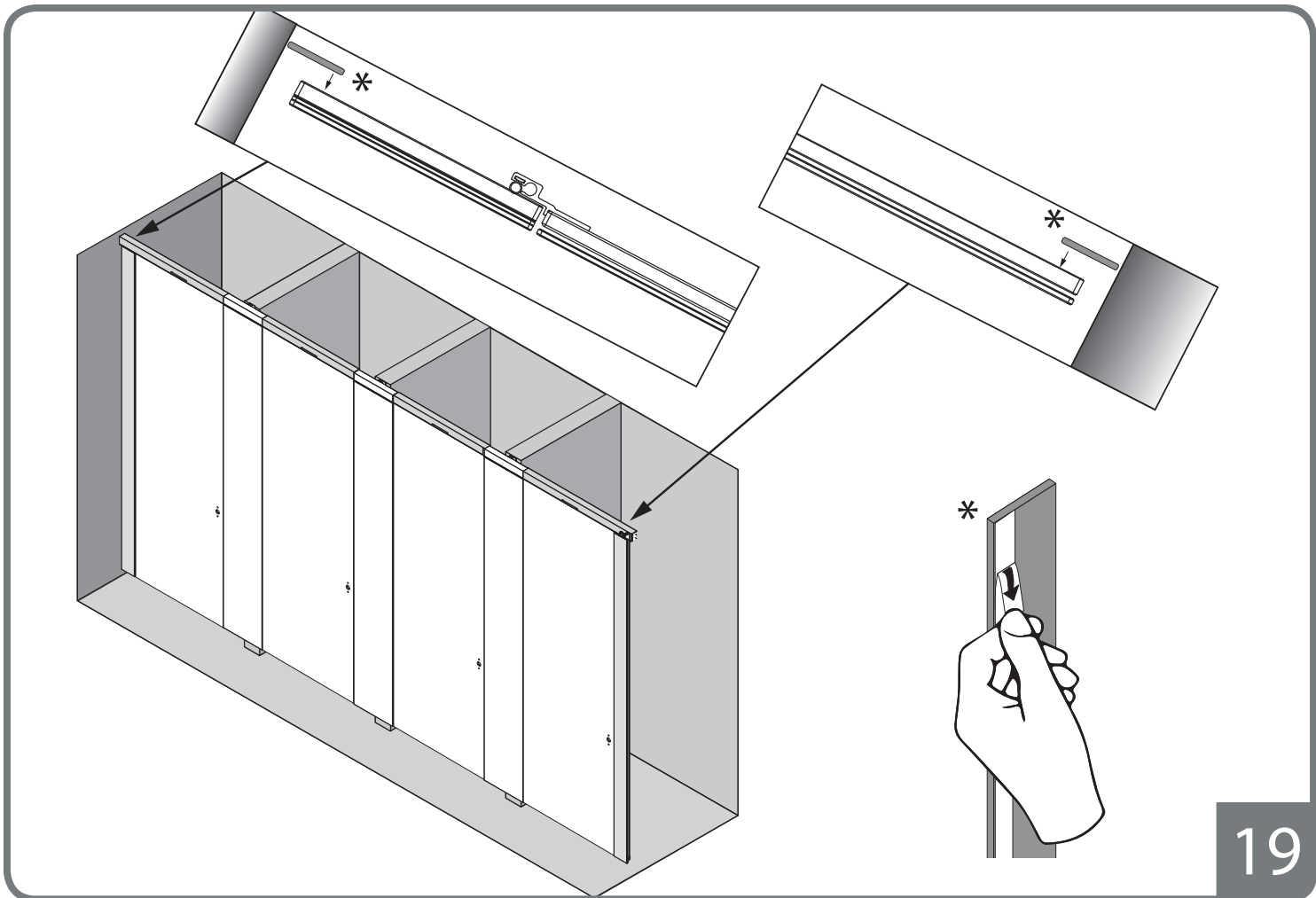
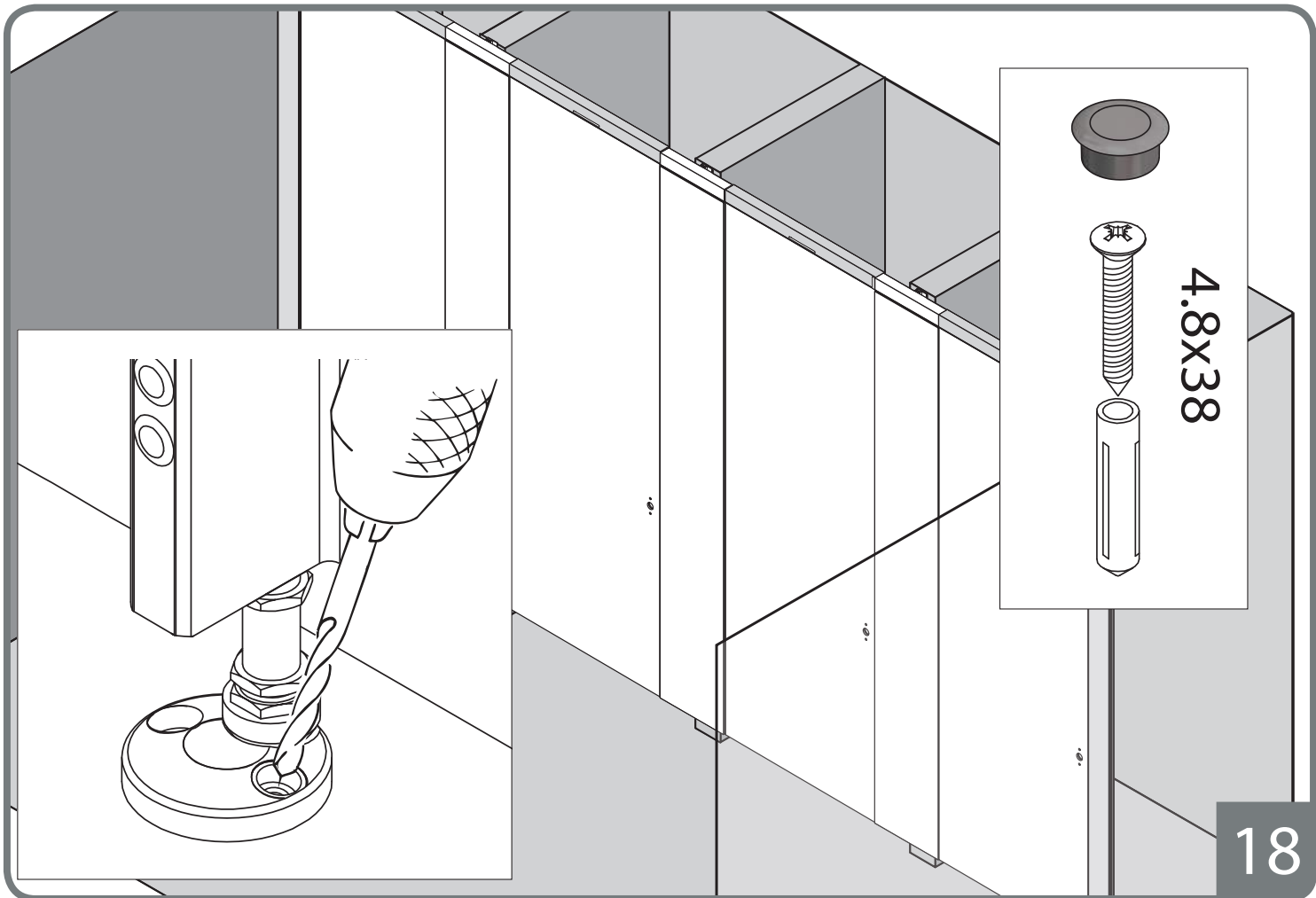

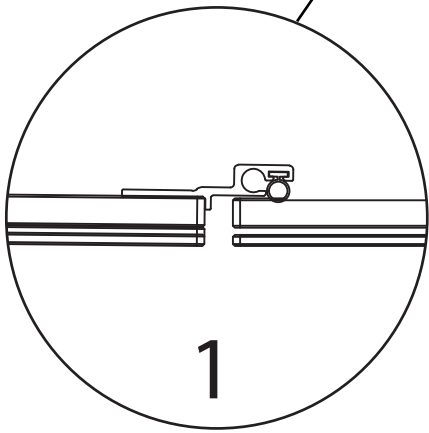
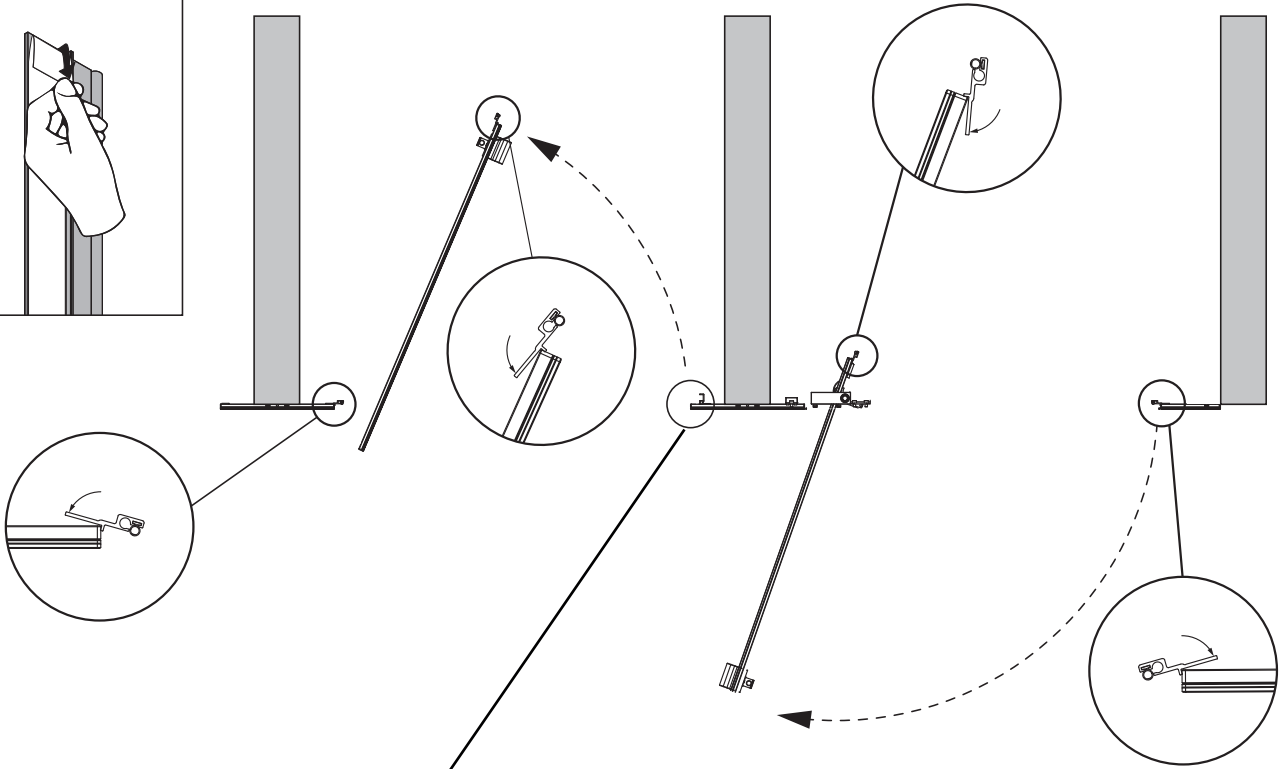
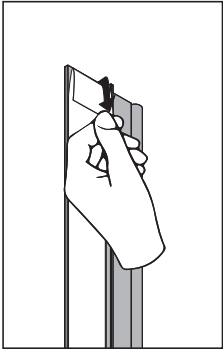

1

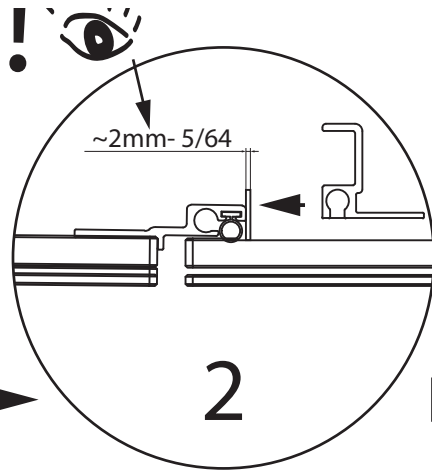

2

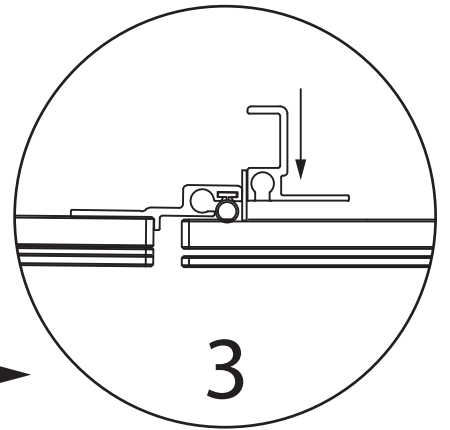

3

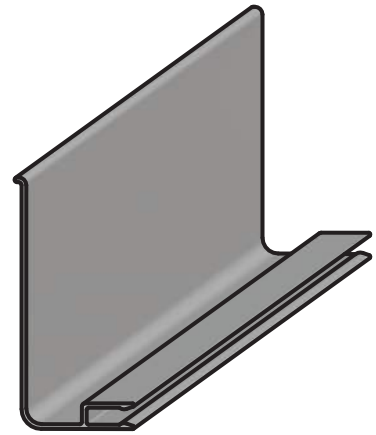
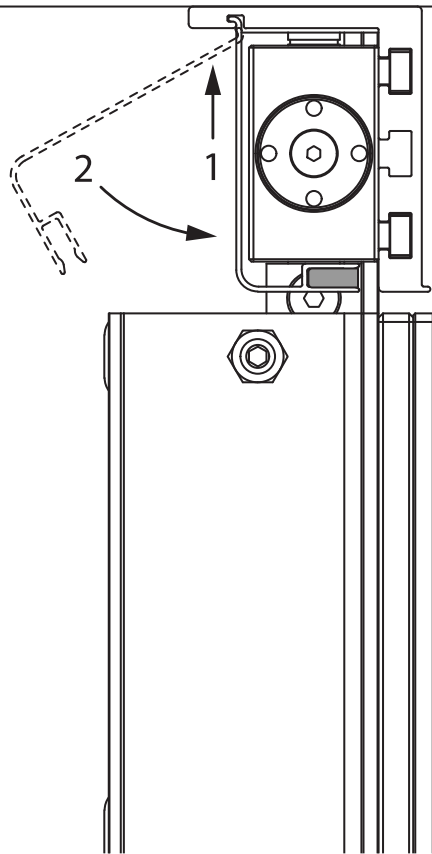

21

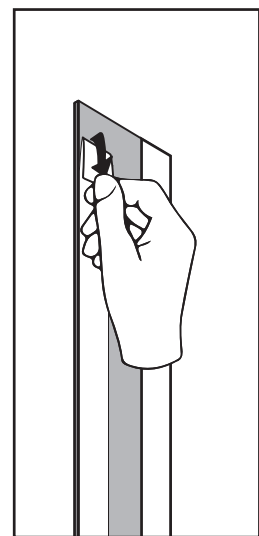
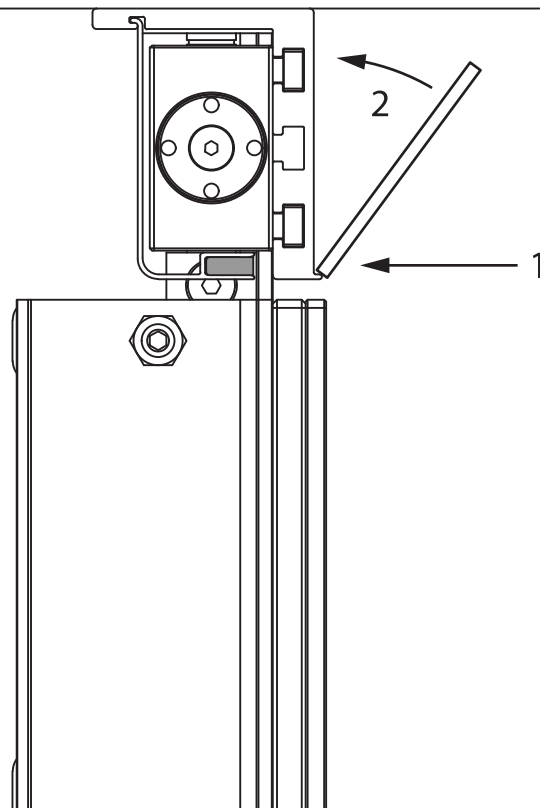

22