

glassSTACKWALL > Frameless



CARVART's STACKWALL > Frameless system is comprised of top-hung glass panels that are captured by top and bottom rails and travel individually along a suspended track and stack and store into a designated parking area. Top tracks can be concealed into the ceiling for minimal look with the advantage of glass panels completely disappear from the opening or be left exposed.

Each solution is custom-tailored to the unique opening dimensions of its respective project and comes with a wide variety of design options that enable architects to configure the final design to a client's exact needs and specifications.

Both Framed and Frameless designs have minimized frame detailing that can be combined with thousands of different CARVART material possibilities, resulting in a tailored appearance in your space, privacy flexibility, acoustical barriers and high-quality performance. This translates into an overall design success that maximizes the visual connection between two adjoining areas.

Specifications

glassSTACKWALL > FRAMELESS

Top-hung glass panels that are captured by top and bottom rails and travel individually along a suspended track and stack and store into a designated parking area. Top tracks can be concealed into the ceiling for minimal look with the advantage of glass panels completely disappear from the opening or be left exposed.

APPLICATIONS

Space division between offices, conference rooms or flex-space.

CONFIGURATIONS

Straight runs, corner applications, custom angles, multiple parking areas, parallel and fully concealed parking areas, mid-run access doors, fixed panels for wide openings.

FUNCTION

Individually movable glass panels divide and open space.

Acoustical Rating: Low-to-moderate due to panel gaps.

Transparent or writable glass.

GLASS TYPES

Laminated, tempered monolithic, tempered laminated.

GLASS FINISHES — *Refer to Finish Chart*
CARVART laminated transparent glass design options available: 01 Core, 02 Color, 03 Pattern, 04 Metallic, 05 Textile, 08 Gradient and 10 Covert.

GLASS THICKNESS —

Refer to local code and structural requirements
 Accommodates 3/8" nominal up to 13/16" nominal.

HARDWARE DIMENSIONS

Aluminum top track: 2-3/4" wide x 3" high nominal.
Top/Bottom finish rails: 1-1/4" deep x 2-3/8" high.

HARDWARE MATERIALS/FINISHES —

Refer to Finish Chart
 Satin anodized aluminum, brushed stainless aluminum, brushed nickel, polished chrome, antique satin chrome, black, antique black.

WIDTHS — OVERALL MINIMUM/ MAXIMUM RANGE (inches):

Glass panels: Maximum 46".
Maximum run lengths (operable or fixed panels): Unlimited.

HEIGHTS — OVERALL MINIMUM/ MAXIMUM RANGE (inches):

Glass panels: Maximum 120" height above finished floors.

MOUNTING FASTENERS

Final anchoring decision is client-directed or based on client structural consultant. Mounting fasteners and anchors to be supplied by others. CARVART advisory available.

VALUE-ADDED BENEFITS

- Efficient hardware make system easy to operate
- Easy to install with self-correcting components
- Wide-range of acoustic and privacy options at all seam and panel connections
- Minimal look with thin, aluminum profiles
- Pre-engineered top structure support solution for taller spaces above finish ceiling (additional cost)
- System durability and long-term integrity
- Turnkey integrated project services

WEIGHT & STRUCTURAL LOADS —

Consult local engineer for structural codes and requirements
 Top rails for individual panels rated up to 220 lbs. Linear per foot weights based on final glass type. Parking system and overall weights available upon request for client structural calculations. Refer to CARVART for technical consultation.

ADD-ON DESIGN OPTIONS —

Per specification and upcharges apply
 Mid-run panel access doors.
 Various pull options.
 Corner extrusion.
 Various plastic/brush connection details for increased privacy.
 Top-structural support available on request and for additional cost.
 Lockable/Non-locking floor latch bolts available.

CUSTOMIZATION

Custom dimensions and parking areas per opening.

INSTALLATION

Simplified panel construction for easy assembly. Self-correcting rollers easily slot into top track. Pre-cut top track speeds up install. Top-track includes seam connectors for improved alignment. Requires trained and competent glazing or carpenter industry professionals. Installation instructions, assistance and training available at time of order. All hardware components, including doors, will be delivered knocked down and require assembly by a glazing industry professional. Certain glass and hardware finishes are available as pre-assembled products as called out in the glass and hardware finishes pages. Consult a CARVART agent for information on available pre-assembled components.

HARDWARE WARRANTY

1-year limited warranty.

For more info, contact CARVART Sales Advisory Team at quotes@carvart.com or call us at 212 675 0030.

Functionality

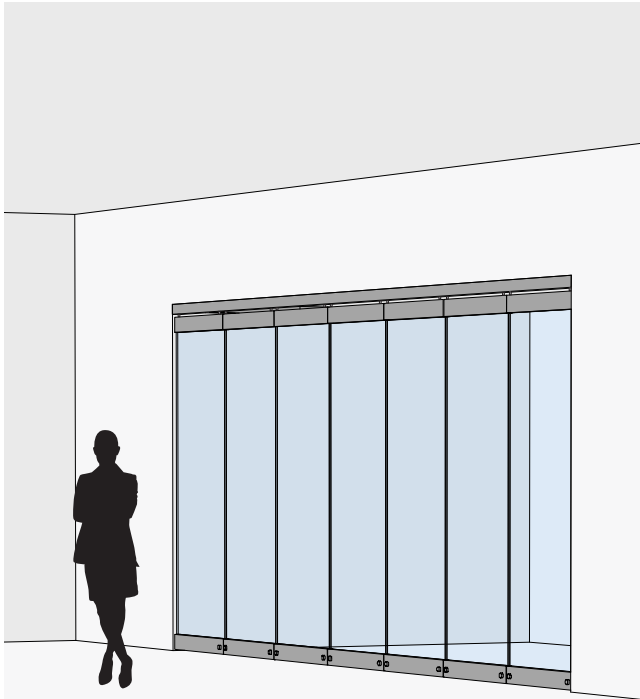

CLOSED



PARTIALLY OPEN

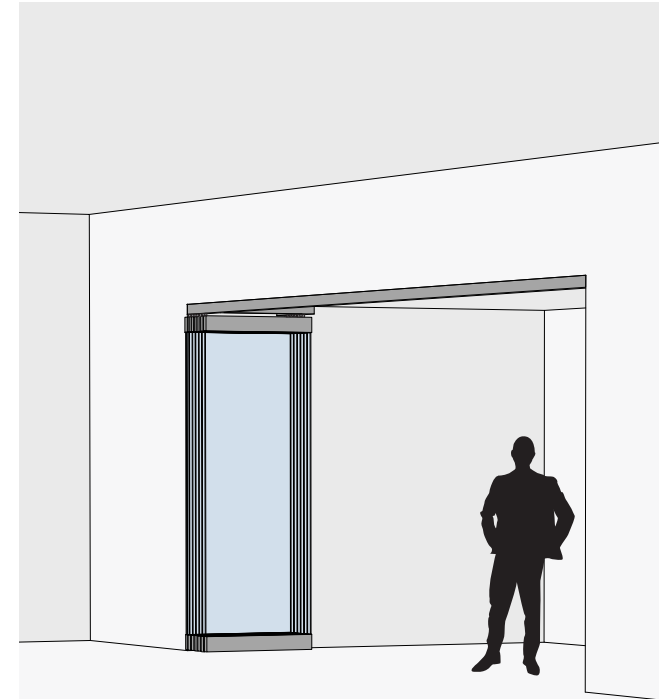

OPEN

Details

TYPICAL FRONT ELEVATION

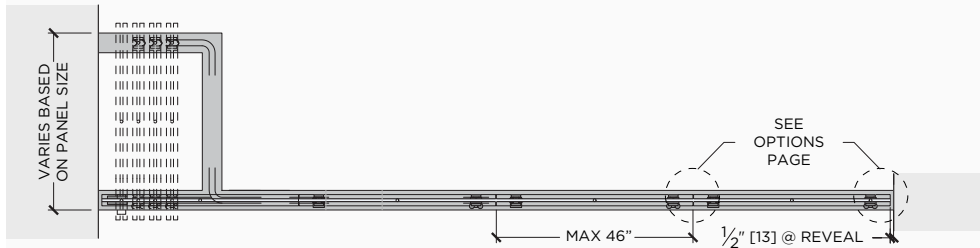
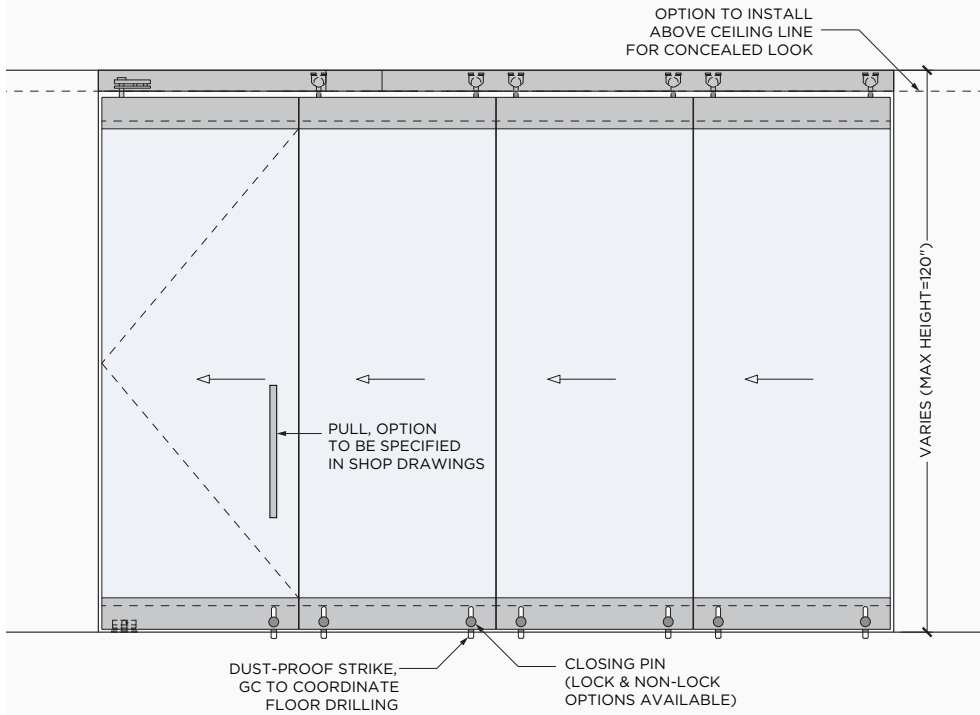

TYPICAL HORIZONTAL SECTION

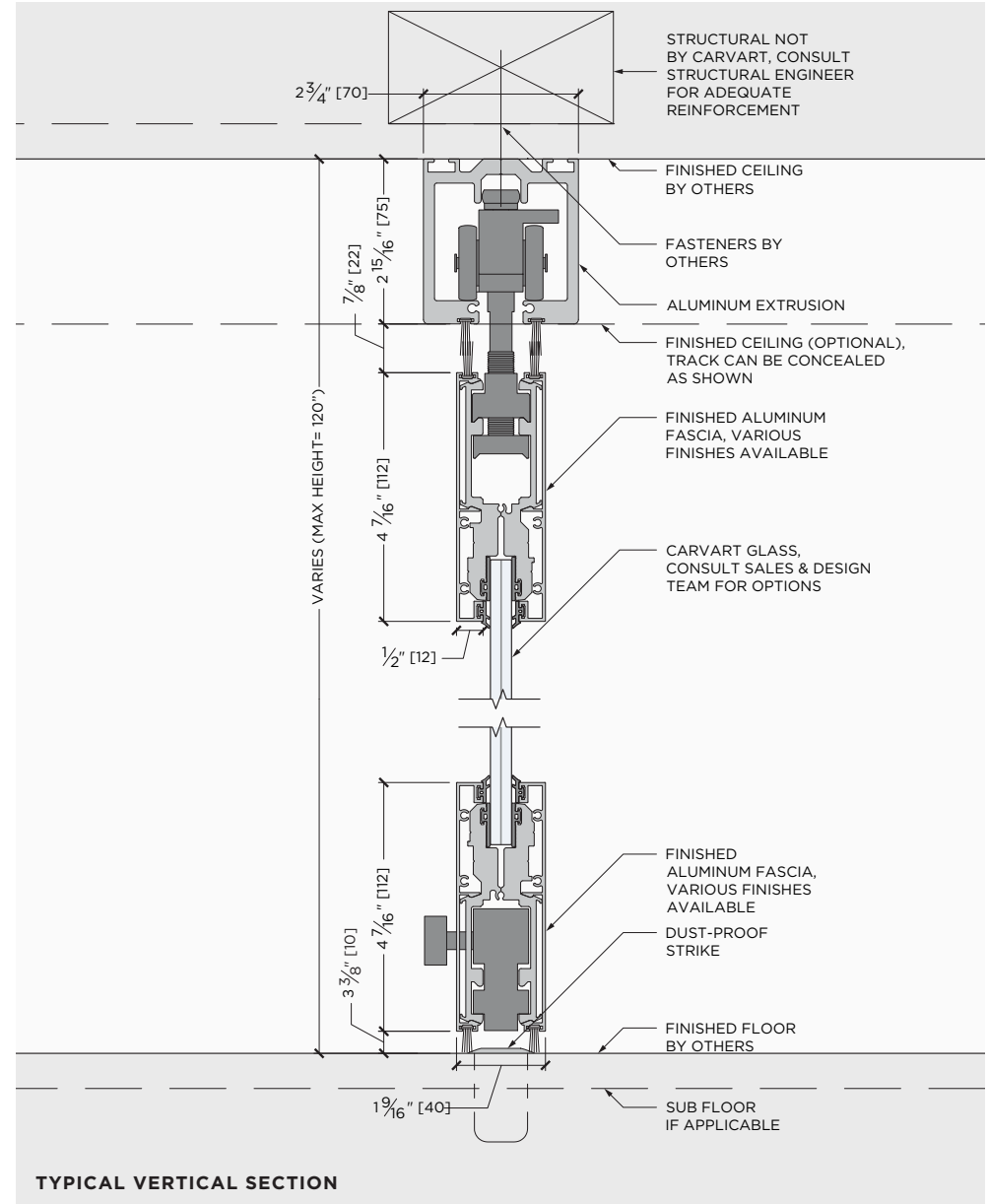

TYPICAL VERTICAL SECTION

Options: Parking area configurations



PG-01
TYPICAL PARKING AREA



PG-04
PARKING W/ CORNER
(VARIED PANEL SIZE OPTION AVAILABLE)



PG-02
PARKING W/ CONCEALED CORNER

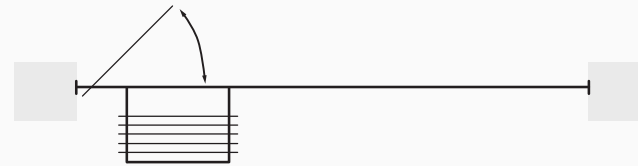

PG-05
PARALLEL PARKING



PG-03
PARKING AREA (WIDE OPENING)

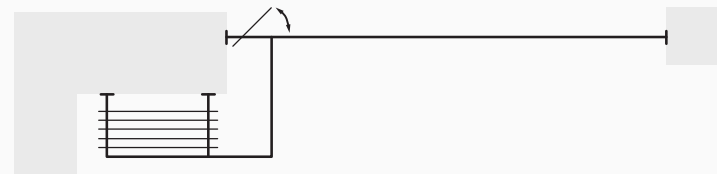

PG-06
PARKING W/ CONCEALED CORNER AND PARALLEL OPTION

Options: Panel types

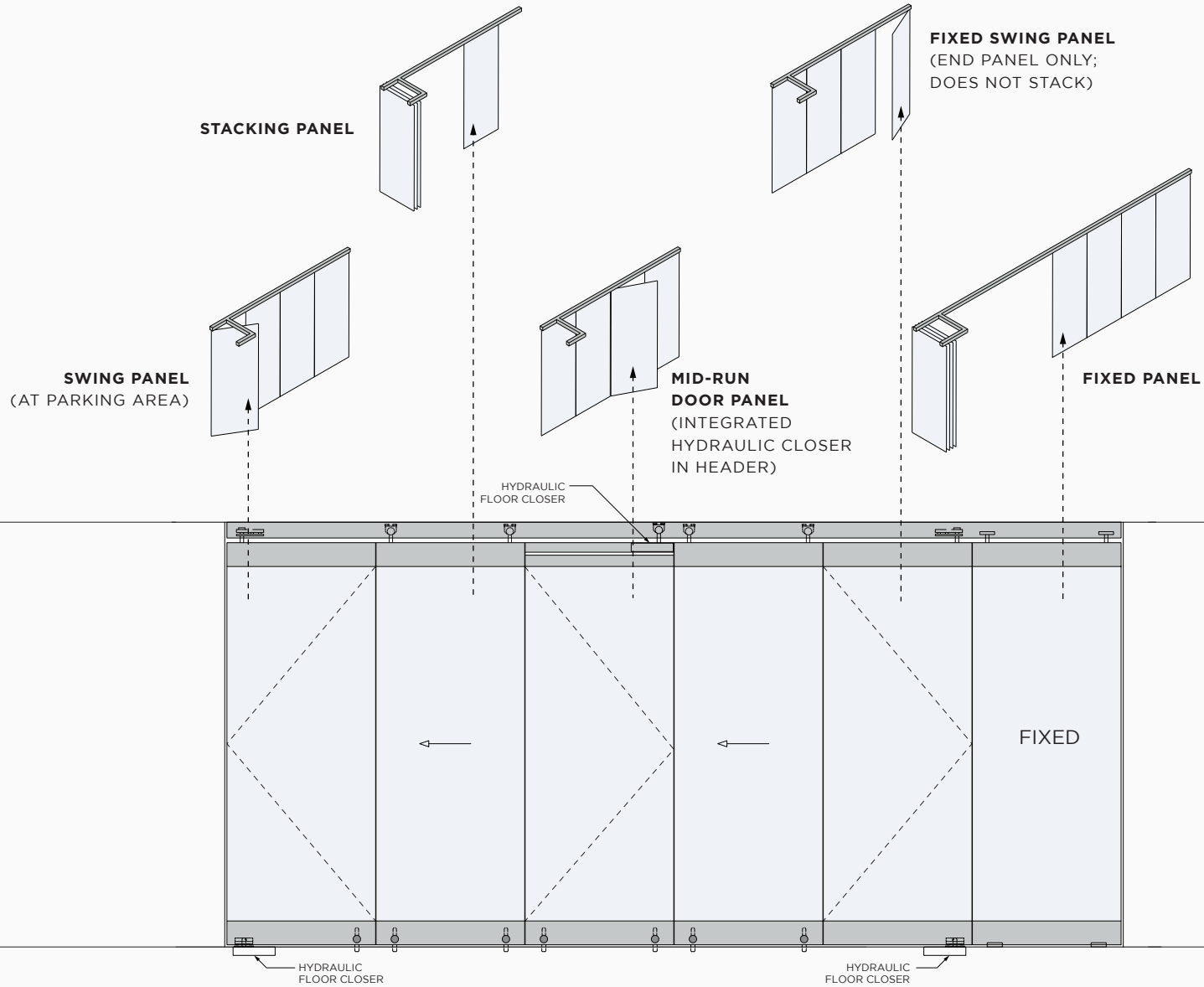

Options: Panel headers

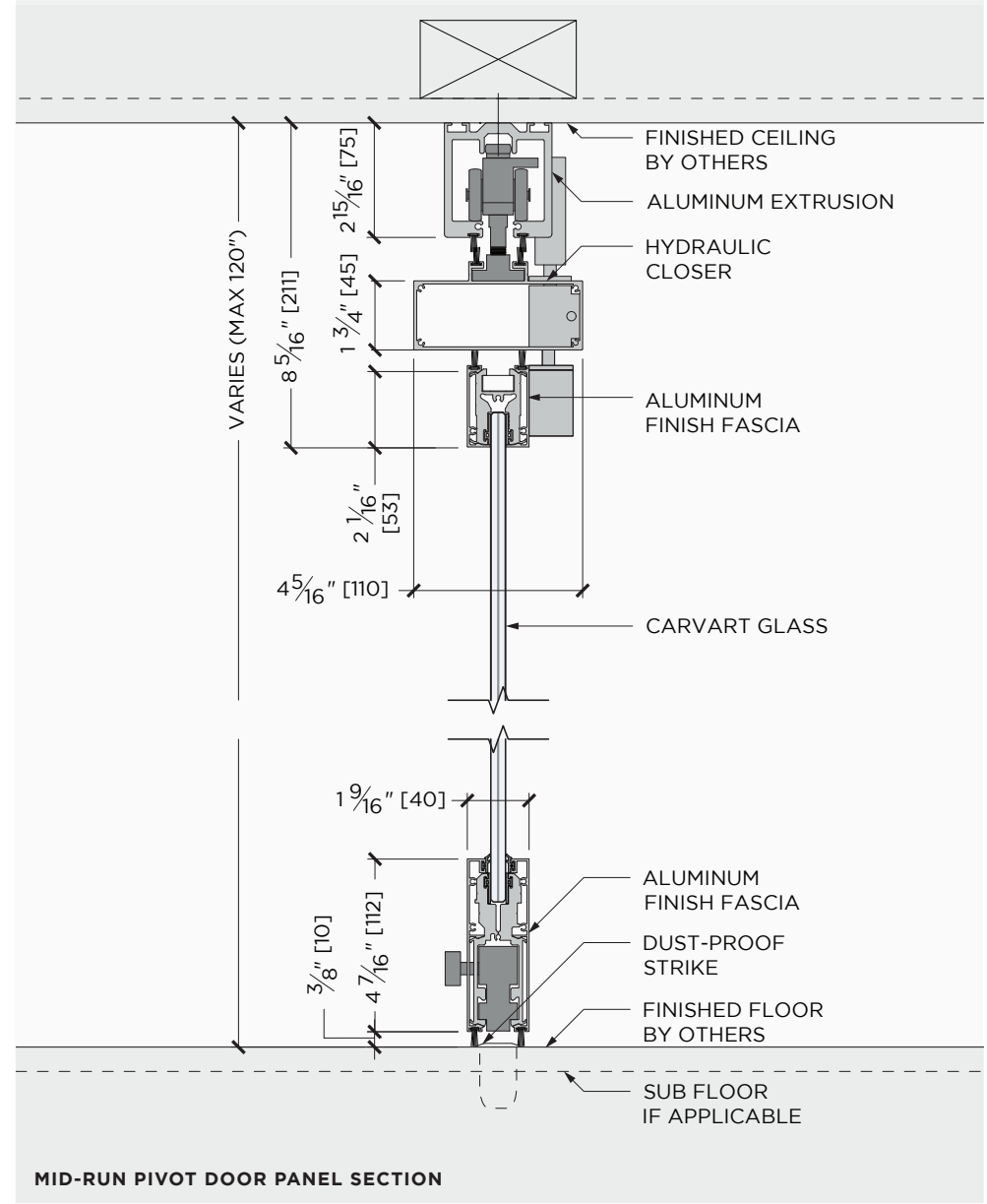
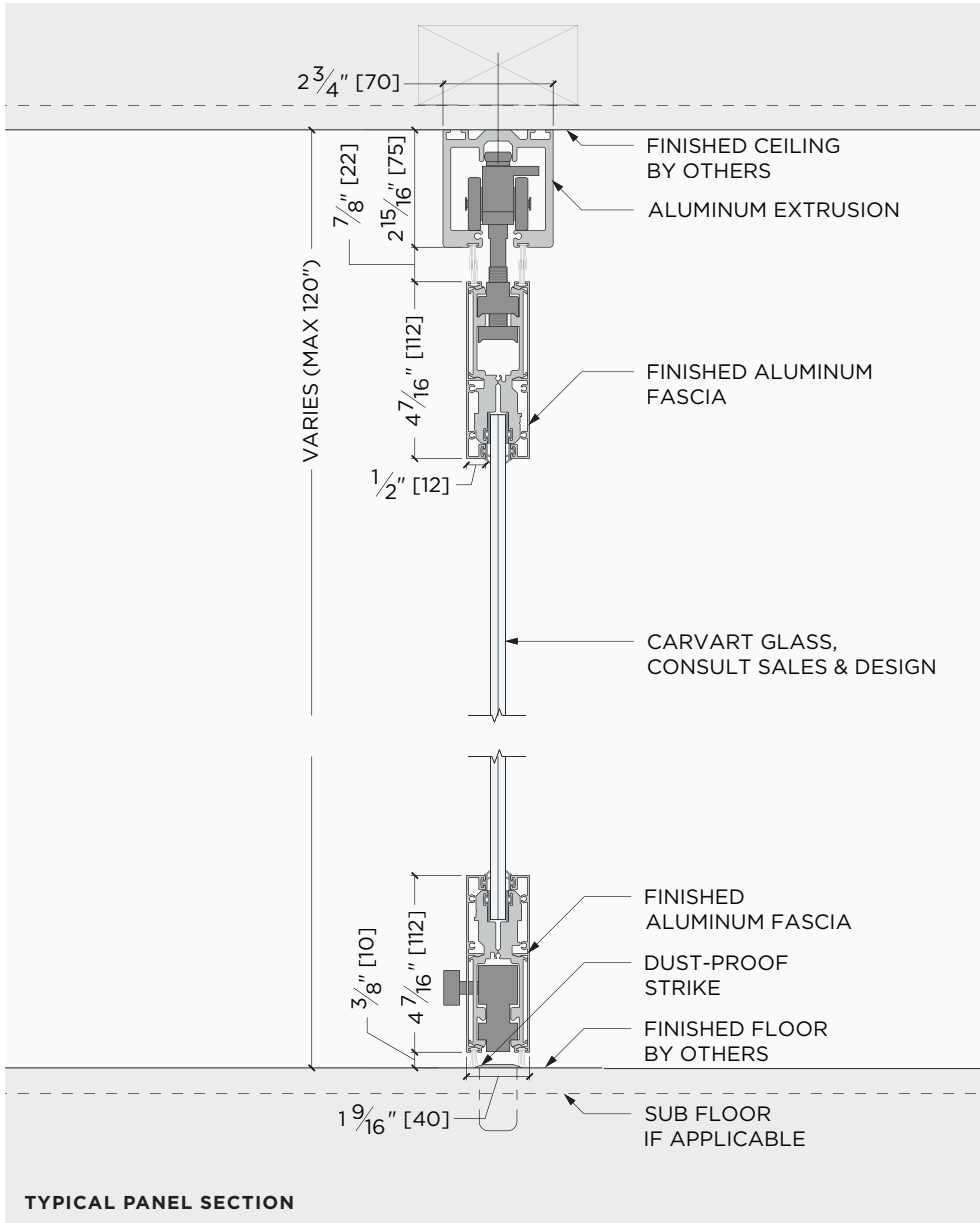

Options: Structural support (above glassWALL systems)

- Pre-engineered, easy-to-install top support can be coordinated and provided for additional cost.
- Ideal for tall spaces where super-structure is far above finish ceiling.

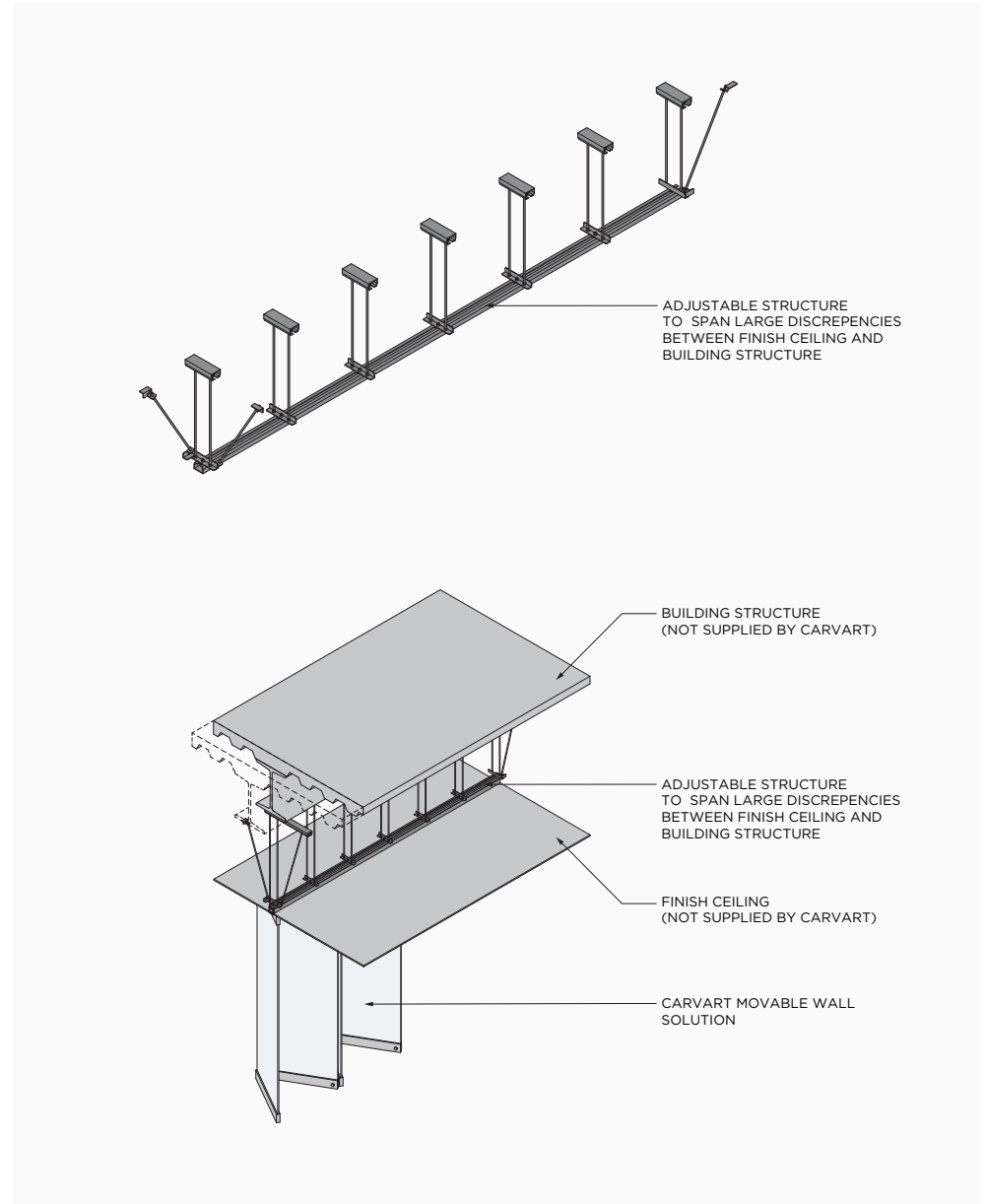
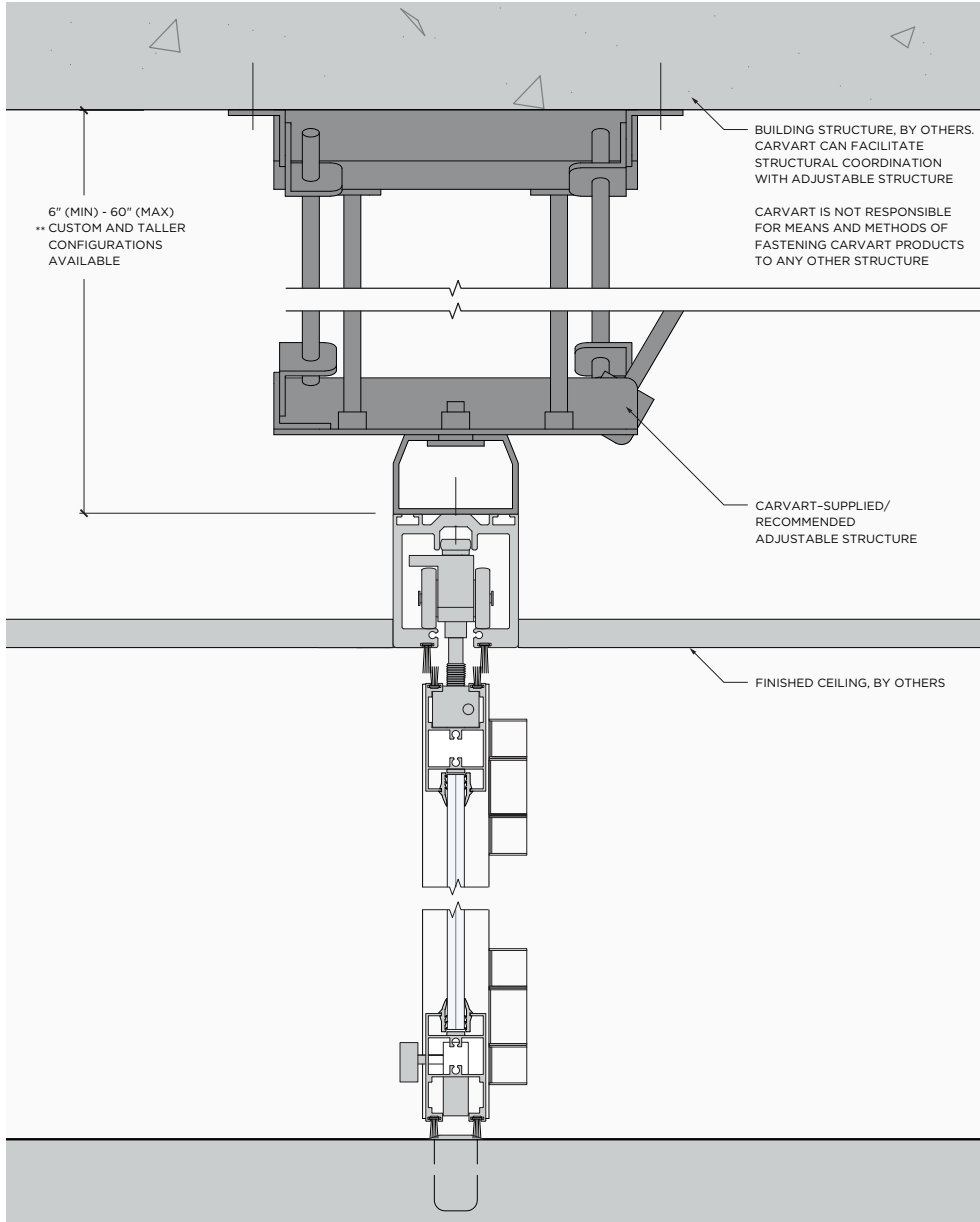

Options: Pulls and Closers

Ladder pulls available in:

- Multiple finishes (see chart)
- ADA configurations
- Locking/non-locking

LADDER PULLS

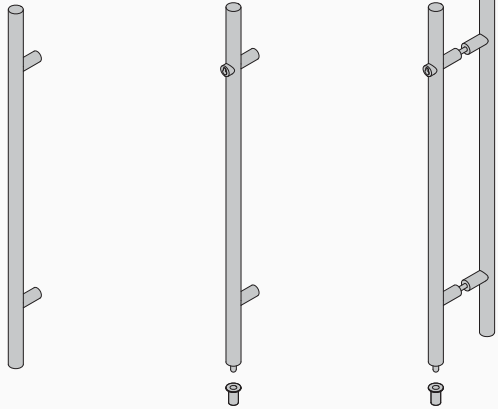

SINGLE-SIDED NON-LOCKING SINGLE-SIDED LOCKING BACK-TO-BACK LOCKING

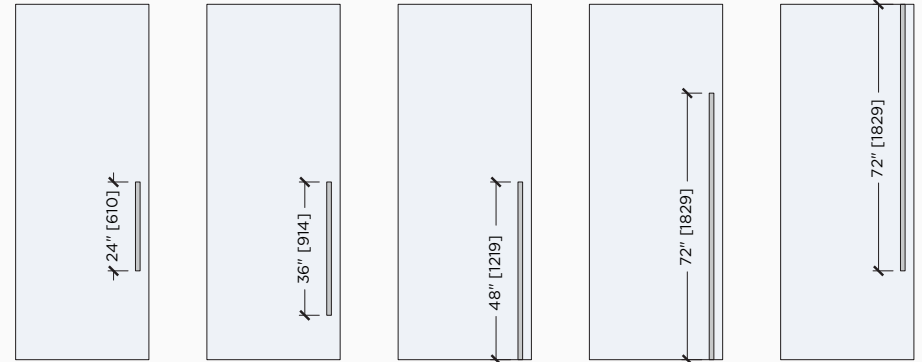

24" NON-LOCKING **36"** NON-LOCKING **48"** LOCKING OR NON-LOCKING **72"** LOCKING OR NON-LOCKING **72"** CEILING CONFIGURATION

CLOSERS

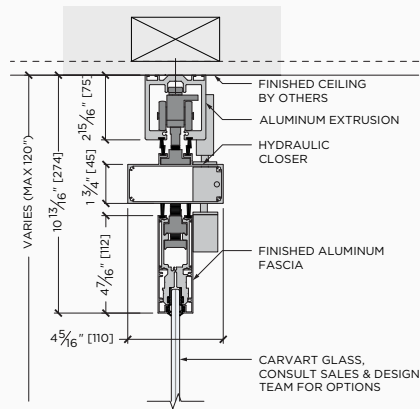

HYDRAULIC DOOR HEADER
@ MID-RUN PANEL DOOR

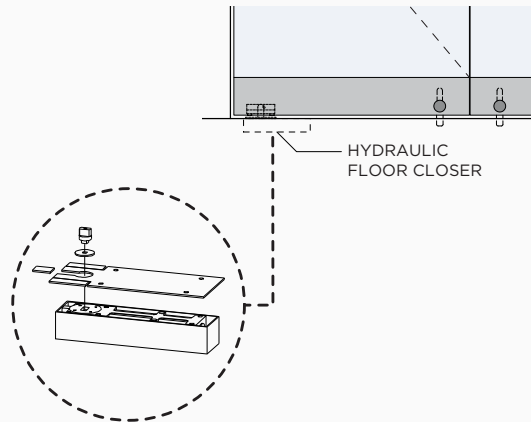

HYDRAULIC FLOOR CLOSER
@ FIXED SWING PANELS

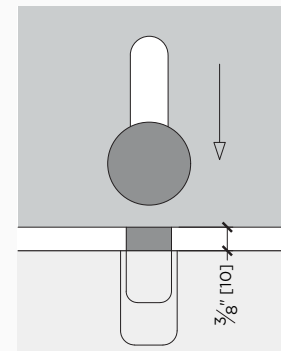

TYPICAL FLOOR BOLT

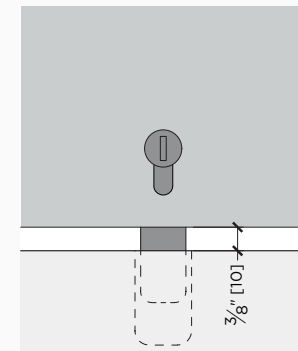

TYPICAL LOCKING BOLT

Options: Connections

Depending on the desired level of acoustic privacy, CARVART offers a range of seals and connection options.

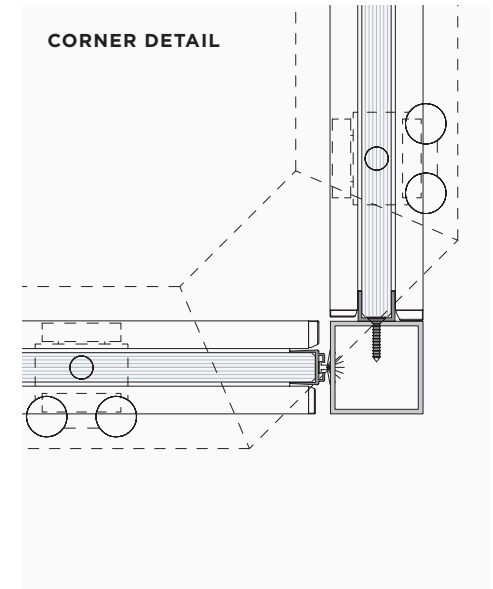
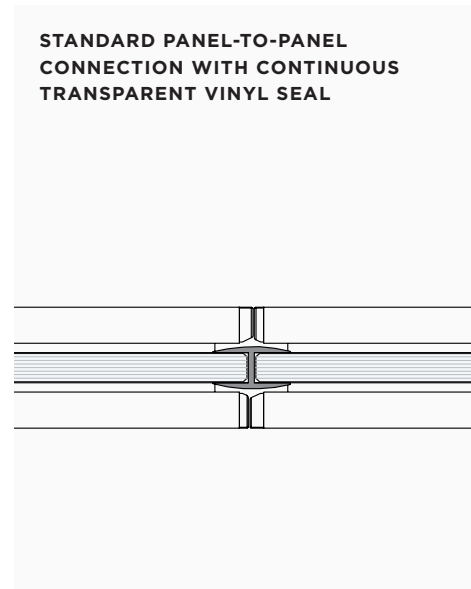
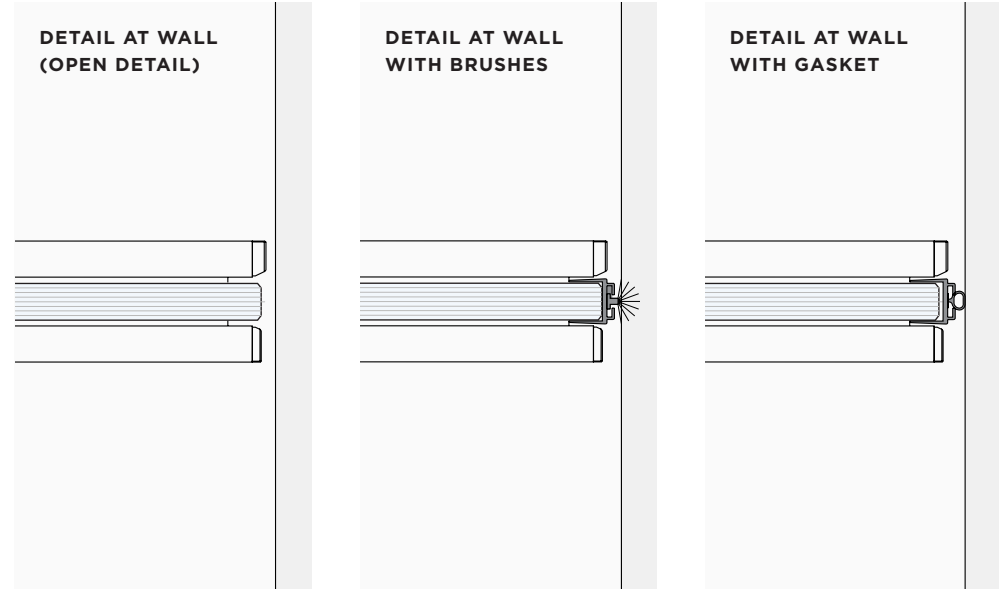
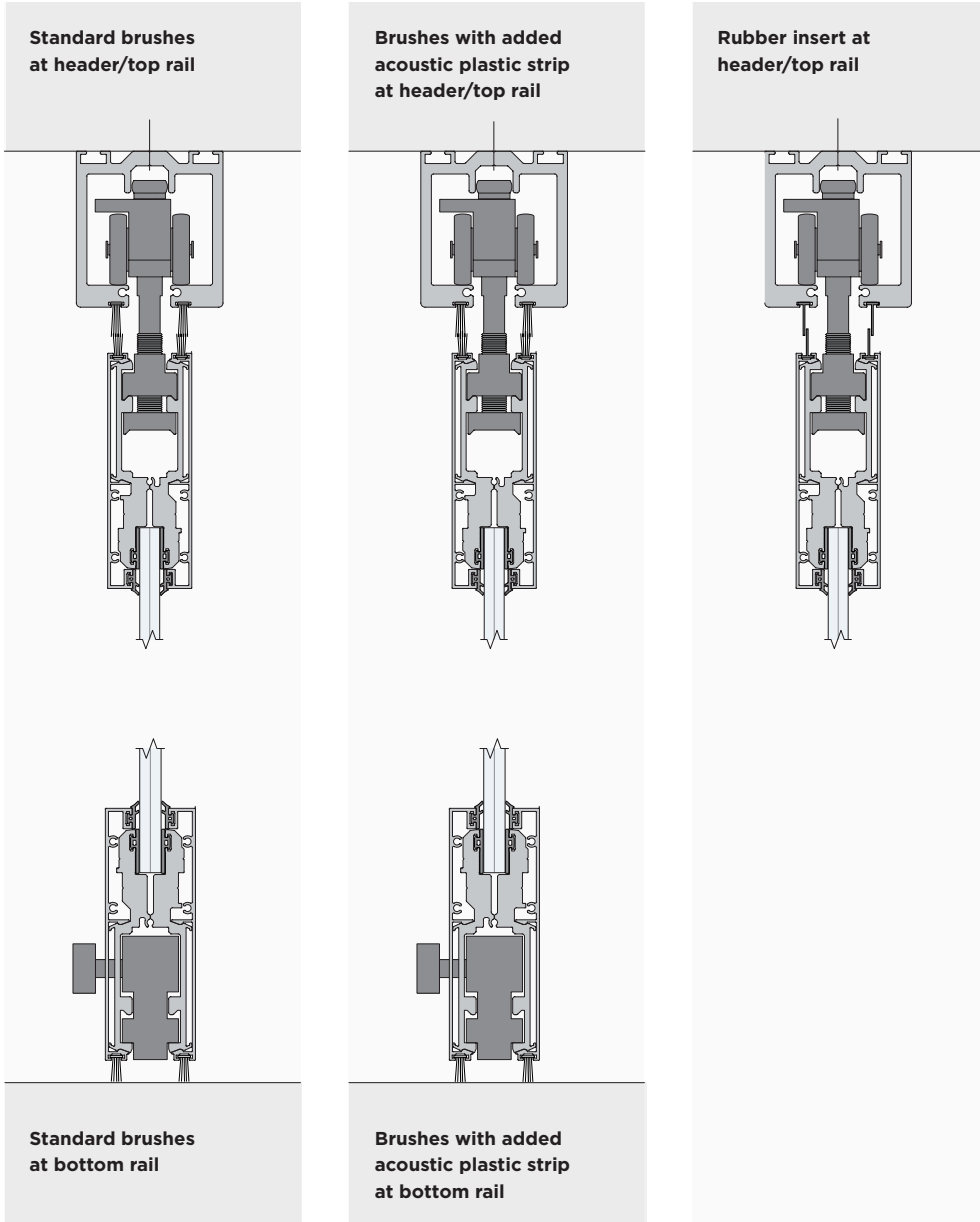

Design appeal and detailing

- All finish profiles and hardware are specifically engineered to keep sight-lines and design aesthetic minimal
- Aluminum fascia's conceal all clamping and hardware, available in various finishes

- Lightweight and optimized hardware solutions keep system efficient and easy to operate
- Create unique appearance with CARVART glass options

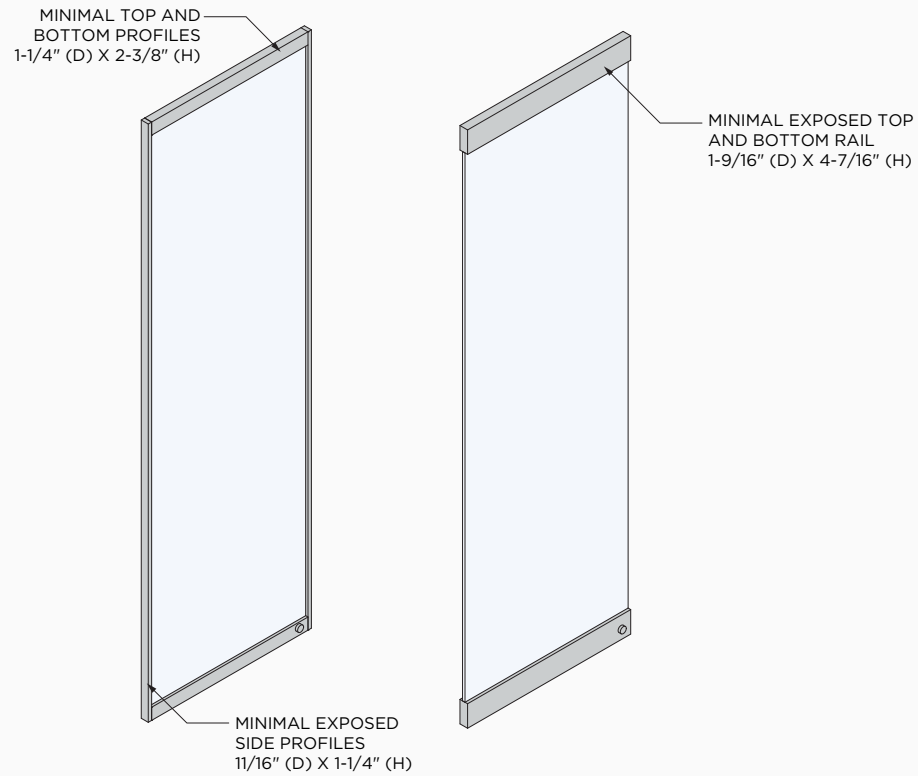

Ease of Installation

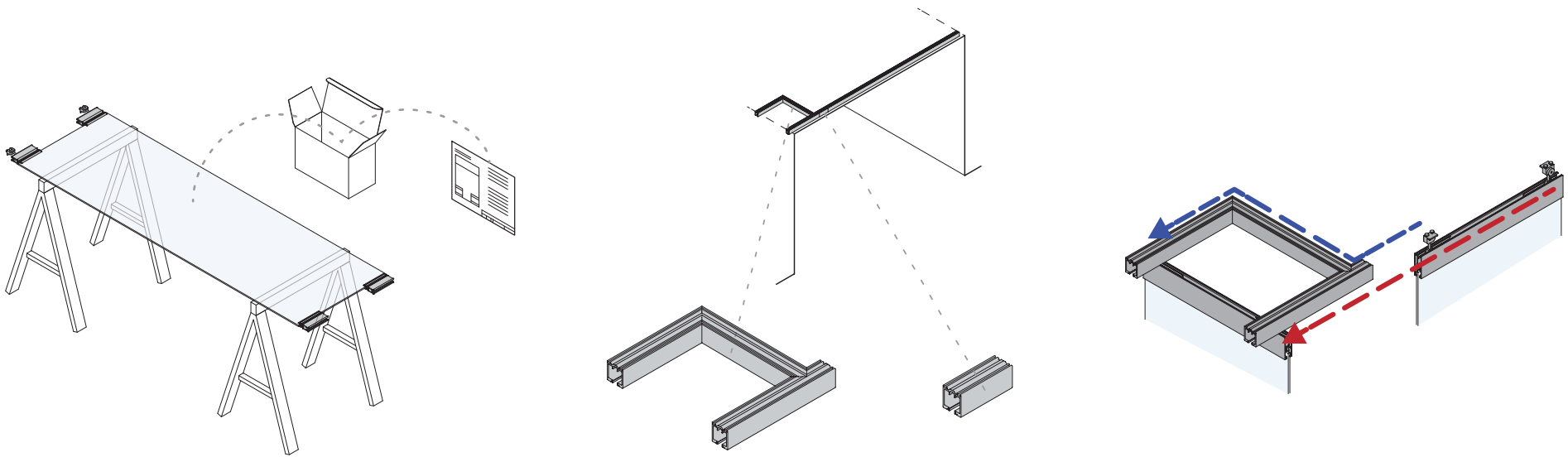

SIMPLE PANEL ASSEMBLY

All hardware components come individually packed per panel and come with individual panel assembly instructions that are labeled to match the shop drawings for easy set up and assembly.

PRE-ASSEMBLED COMPONENTS

Easy-to-install top track: parking areas, removable maintenance piece and lengths of top track come pre-cut and assembled making it easy and fast to install.

SELF-GUIDED HARDWARE

All hardware is self-guided to prevent any incorrect installation or operation.

Life cycle maintenance

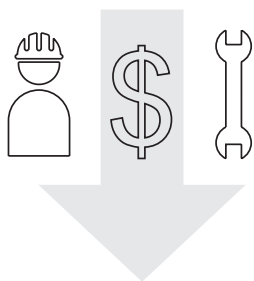

LOW LABOR COST

Conventional systems have much higher labor costs due to complex installation methods. CARVART glassRAILING products are designed to be light-weight and ergonomic to facilitate easy installation.

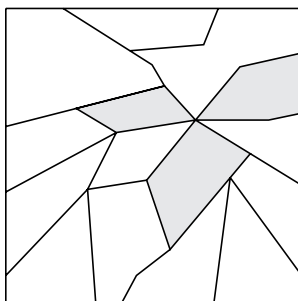

EASY TO REPLACE

Intermediate panels are removable and replaceable due to dry-glazed system.

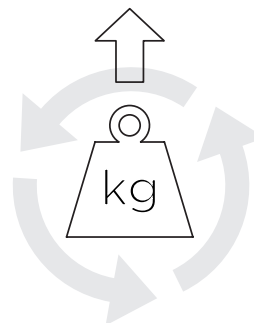

DURABILITY AND HIGH CYCLE TESTING

All CARVART movable walls are cycled-tested to hundreds of thousands of cycles and rated for weights far beyond the maximum panel size.

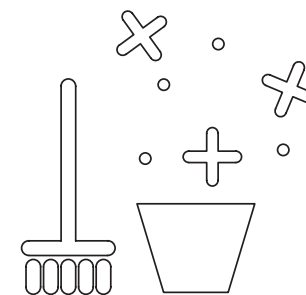

CLEANING AND MAINTENANCE

Virtually no maintenance outside of cleaning once the system is in place and installed. Profiles have minimum reveals and crevices to collect dirt and grime.

Project management coordination

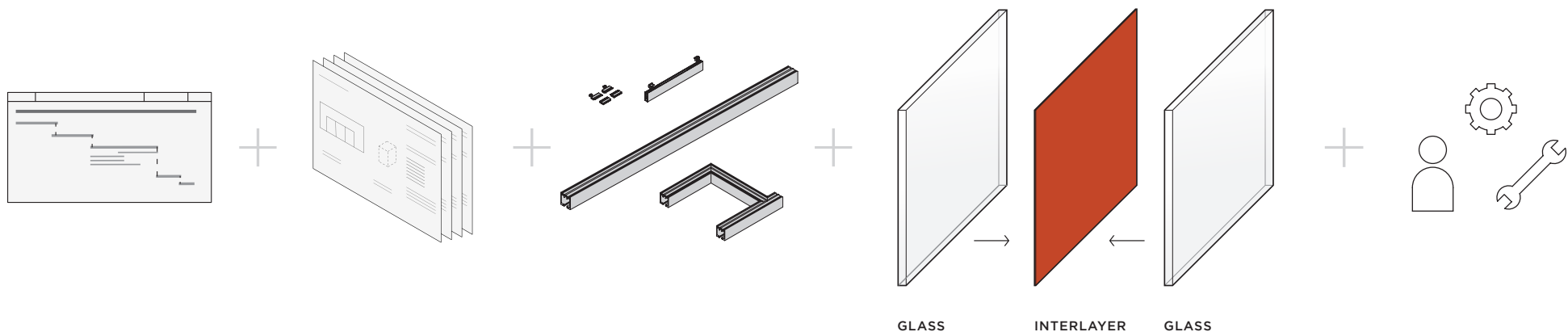

COORDINATION AND SHOP DRAWINGS

- CARVART offers full scheduling coordination and phasing for custom project delivery
- Full range of coordination and shop drawing/ engineering services
- Dedicated project managers are assigned to each project for maximum success

HARDWARE OPTIONS

- Provide full range of hardware options for infinite design and site conditions
- Multiple design options

GLASS DESIGN AND DEVELOPMENT

- Glass design and development services integrate standard and custom glass selections with available hardware options

POST-DELIVERY SERVICES

- Installation training that is specific to project and product
- Project-specific service levels (including phased deliveries and shipping)
- Project logistics can ship by floor or designated area

Overview

CURATED MATERIALS

CARVART's team and resources bring an innovative spirit and celebrates the creative process. Our strength is solving design challenges with sophisticated detailing, engineering and a cohesive blend of materials across CARVART's minimalist interior and exterior architectural products and hardware systems.

CARVART empowers the creative process by curating an inspiring material offering of glass, stone, wood, cHPL, metals, meshes, textiles and more with patterns, textures, finishes and levels of transparency and reflectivity that allows creators to accurately envision their design.

GUIDELINES

- Materials appropriate for each system vary in size, thickness, type, weight and other associated properties.
- Explore each material for inspiration at carvart.com/materials and see full material palettes.
- Due to the various ways of creating with these materials, please consult a CARVART team member to ensure your material is best suited for a specific architectural product application.
- Materials can be integrated into CARVART's architectural system or available in sheets.

visit carvart.com/materials

GLASS

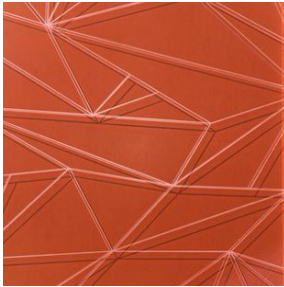

Color
Translucency & Reflectivity
Interlayer
Pattern & Texture
CARVART Digital Experience

cHPL



Color
Woodgrain
Rock
Metal
Polaris

STONE

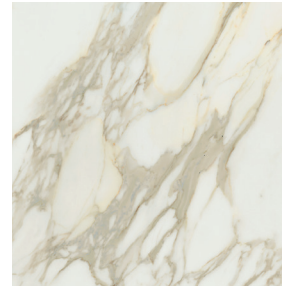

Porcelain

WOOD



Natural Veneer
Reconstituted Veneer
Perforation Patterns

METAL

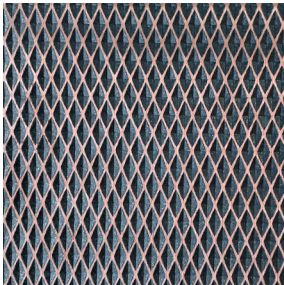

Copper Plated
Powder Coated

MESH

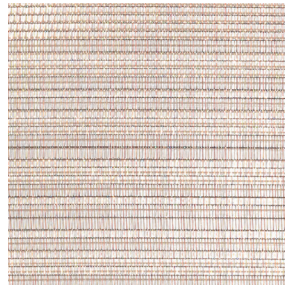

Glass Interlayer
Wire Mesh

TEXTILE



Acoustical COM

WALL COVERING

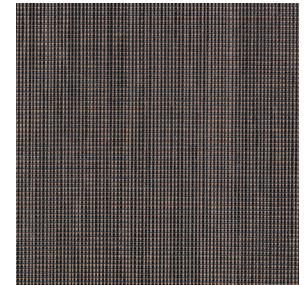

Acoustical COM

Overview

CURATED HARDWARE FINISHES

CARVART's team and resources bring an innovative spirit and celebrates the creative process. Our strength is solving design challenges with sophisticated detailing, engineering and a cohesive blend of materials and hardware finishes across CARVART's minimalist interior and exterior architectural products and systems.

CARVART empowers the creative process by curating hardware system finishes from natural anodized aluminum with polish, satin, brushed, antiqued, blackened and other elegant techniques as well as the option to select any RAL color for powder coating.

- Hardware finishes appropriate for each system may vary in color, type and other properties.
- Explore finish options below and consult with a CARVART team member for custom capabilities.

visit carvart.com/materials

SATIN ANODIZED ALUMINUM



MFSA

POLISHED ALUMINUM



MFPA

BLACK ANODIZED ALUMINUM

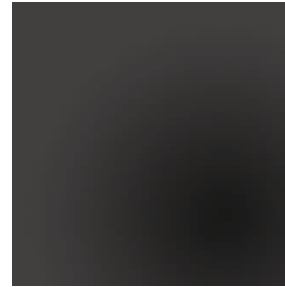

MFBA

BLACKENED ALUMINUM



MFBB

BRUSHED ANTIQUE NICKEL



MFBN

BRUSHED SATIN NICKEL



MFNK

RAL POWDER COAT



Select any RAL Color

CARVART®