

glassWALLS Simple



CARVART offers three diverse and aesthetically progressive options for glass office front partition systems. Each is designed with a minimal focus on site-lines, easy installation and a wide range of functional design options to successfully configure any office layout. The line provides for creating uniqueness and fresh visual appeal with a range of choices: minimal, frameless looks or fully-framed solutions, both that are high on privacy and acoustics without losing an aesthetic integrity. For those facilities in search of a warehouse-style appearance, all three systems provide for applied mullions that delivers great looking segmented visuals across the wall. The CARVART Slim and Simple lines are available with a total of nine different opening and door options including sliding and swing doors and a range of interchangeable details where designers can tailor each project layout to address the visual image and performance requirements for individual offices and conferences rooms throughout a facility.

With a wide range of metal finishes and glass options to customize any look or performance level, the CARVART glassWALLS > Officefronts offer a near-infinite selection of design options to complement any sleek office design while delivering the highest level of standard in quality, design integrity and uniqueness.

Specifications

glassWALLS > Simple

Innovative extrusions and easy installation make the glassWALLS > Simple Frame a unique solution to any office front design. With a multitude of door and opening options, configurations for dividing office spaces are essentially endless. The Simple Frame extrusion is composed of a two-piece channel and incorporates wedge vinyl that both facilitate easy installation. Benefits also include ADA compliant features and accessories, easy maintenance and a wide range of metal finishes that can complement CARVART's glass offering. The system also integrates seamlessly with CARVART's glassPOST accessories that allow designers to further customize spaces and add functionality.

FACILITY DESIGN APPLICATIONS

Office separation, open space configurations, door and opening division, space division between offices, conference rooms or flex-space.

CONFIGURATIONS

Straight runs, endless fixed panel, custom angles and configurations, various heights, fronts only, 2-4 sided office arrangements.

FUNCTION

Fixed panels, hinged/pivot/sliding door integration available.

GLASS TYPES

Tempered monolithic, laminated, tempered laminated.

GLASS FINISHES — Refer to Finish Chart

CARVART laminated transparent glass design options available: 01 Core, 02 Color, 03 Pattern, 04 Metallic, 05 Textile, 08 Gradient and 10 Covert.

SURFACES

Smooth glass.
Etched glass.

GLASS THICKNESS —

Refer to local code and structural requirements
Accommodates 3/8" nominal up to 1/2" nominal.

HARDWARE DIMENSIONS

Aluminum extrusion height: 1-3/4"
Aluminum extrusion depth: 1-13/16"

HARDWARE MATERIALS/FINISHES —

Refer to Finish Chart
Brushed satin anodized aluminum, polished aluminum, black, white, grey, midnight, charcoal, light grey, warm grey, champagne, terra cotta, blackened aluminum.

WIDTHS — OVERALL MINIMUM/ MAXIMUM RANGE (inches):

Glass Panels: Minimum 6" and maximum 48" (custom and larger sizes available upon request and depending on engineering limits).
Maximum opening lengths: Unlimited.

VALUE-ADDED BENEFITS

- Multiple door and opening options
- Wide range of CARVART pulls available
- Two-piece channel makes installation easy
- Multiple metal finishes available
- ADA compliant hardware and configurations available
- Power and data integration available with snap-on cable management
- System durability and long-term integrity
- Turkey project services

HEIGHTS — OVERALL MINIMUM/ MAXIMUM RANGE (inches):

Minimum 9" height; maximum 108" height above finished floors (custom and larger sizes available upon request and depending on engineering limits).

MOUNTING FASTENERS

Final anchoring decision is client-directed or based on client structural consultant.
Mounting fasteners and anchors to be supplied by others.
CARVART advisory and coordination available.

WEIGHT & STRUCTURAL LOADS —

Consult local engineer for structural codes and requirements
Sliding door track capacities rated for 200 lbs.
Overall weights available upon request for client structural calculations.
Refer to CARVART for technical consultation.

ADD-ON DESIGN OPTIONS —

Per specification and upcharges apply
Pulls, swing and sliding doors, glassPOST integration.

CUSTOMIZATION

Custom dimensions per opening.

INSTALLATION

Two-piece extrusion and adjustable levelers facilitate easy installation and glass loading. Requires trained and competent glazing or carpenter industry professionals. Installation instructions, assistance and training available at time of order. All hardware components, including doors, will be delivered knocked down and require assembly by a glazing industry professional. Certain glass and hardware finishes are available as pre-assembled products as called out in the glass and hardware finishes pages. Consult a CARVART agent for information on available pre-assembled components.

HARDWARE WARRANTY —

5-year limited warranty.

For more info, contact CARVART Sales Advisory Team at quotes@carvart.com or call us at 212 675 0030.

Simple > Framed Hinge Door

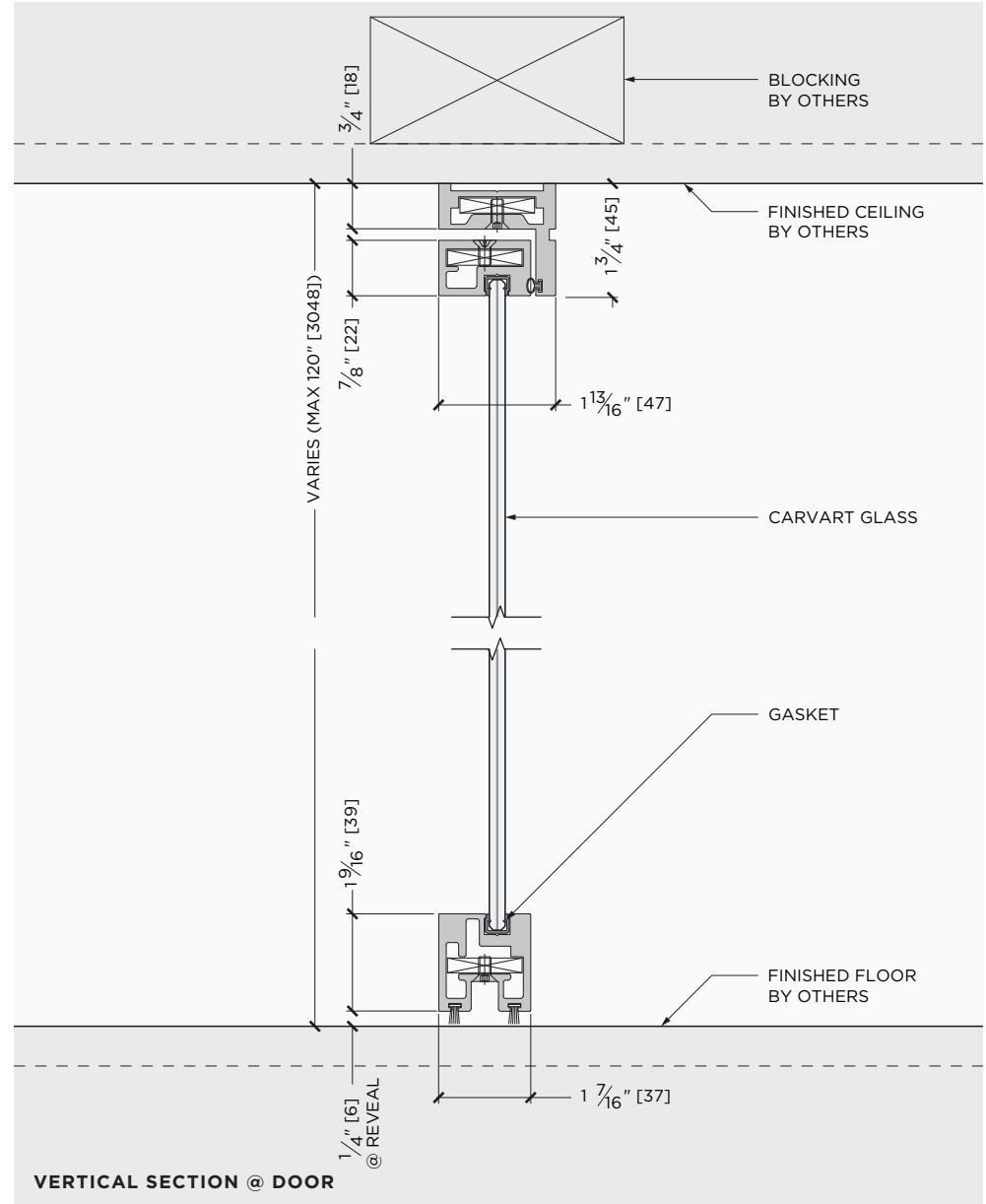
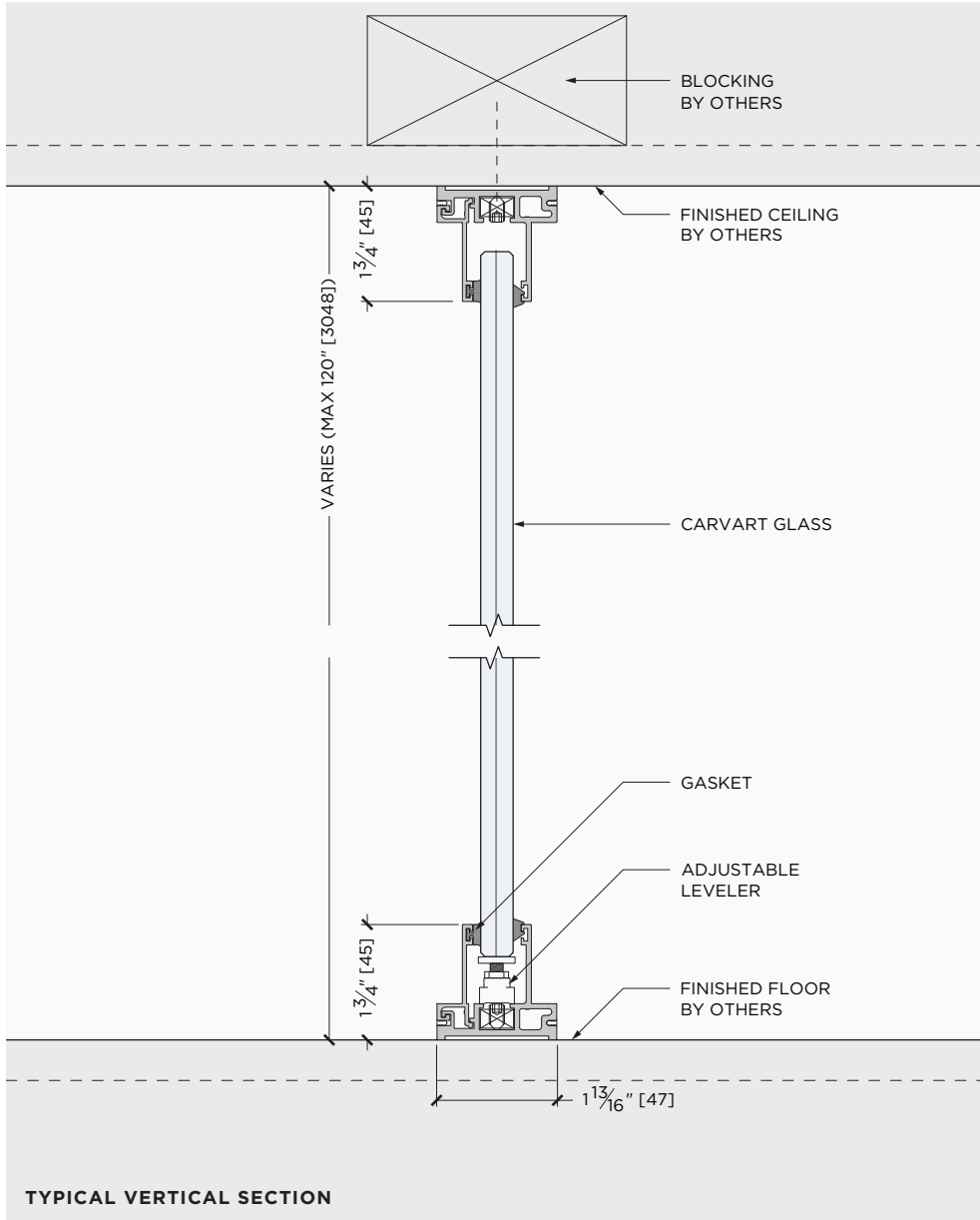

Simple > Frameless Pivot Door (with Continuous Header)

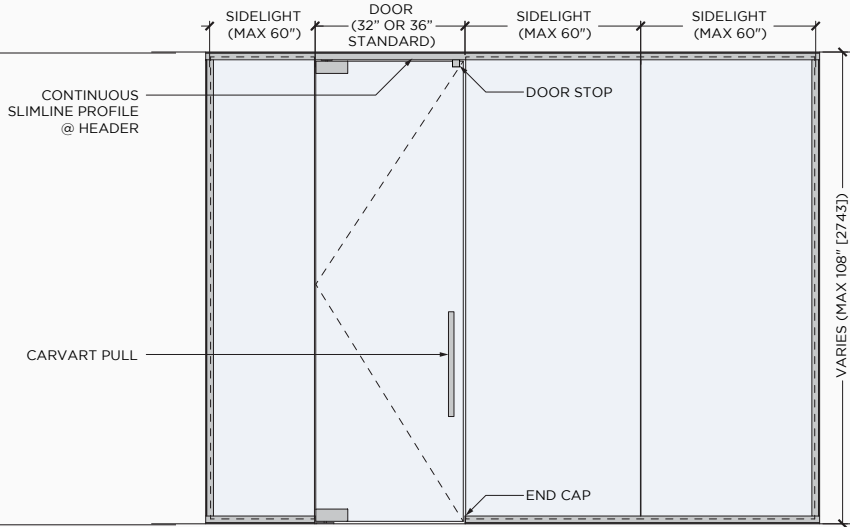

TYPICAL FRONT ELEVATION

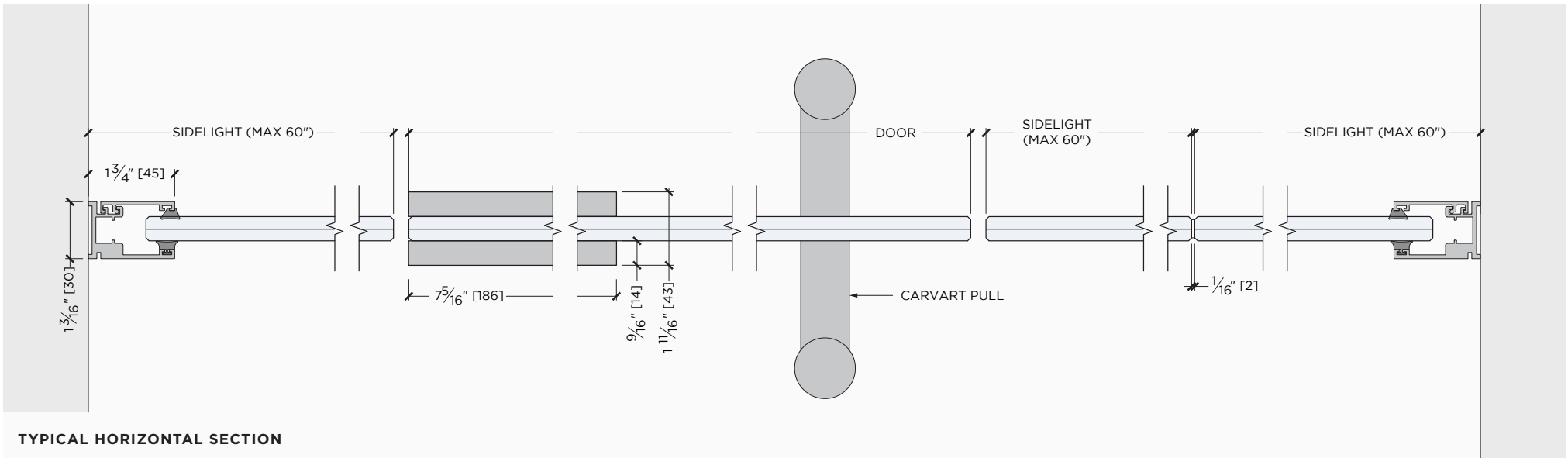

TYPICAL HORIZONTAL SECTION

Simple > Frameless Pivot Door (with Continuous Header)

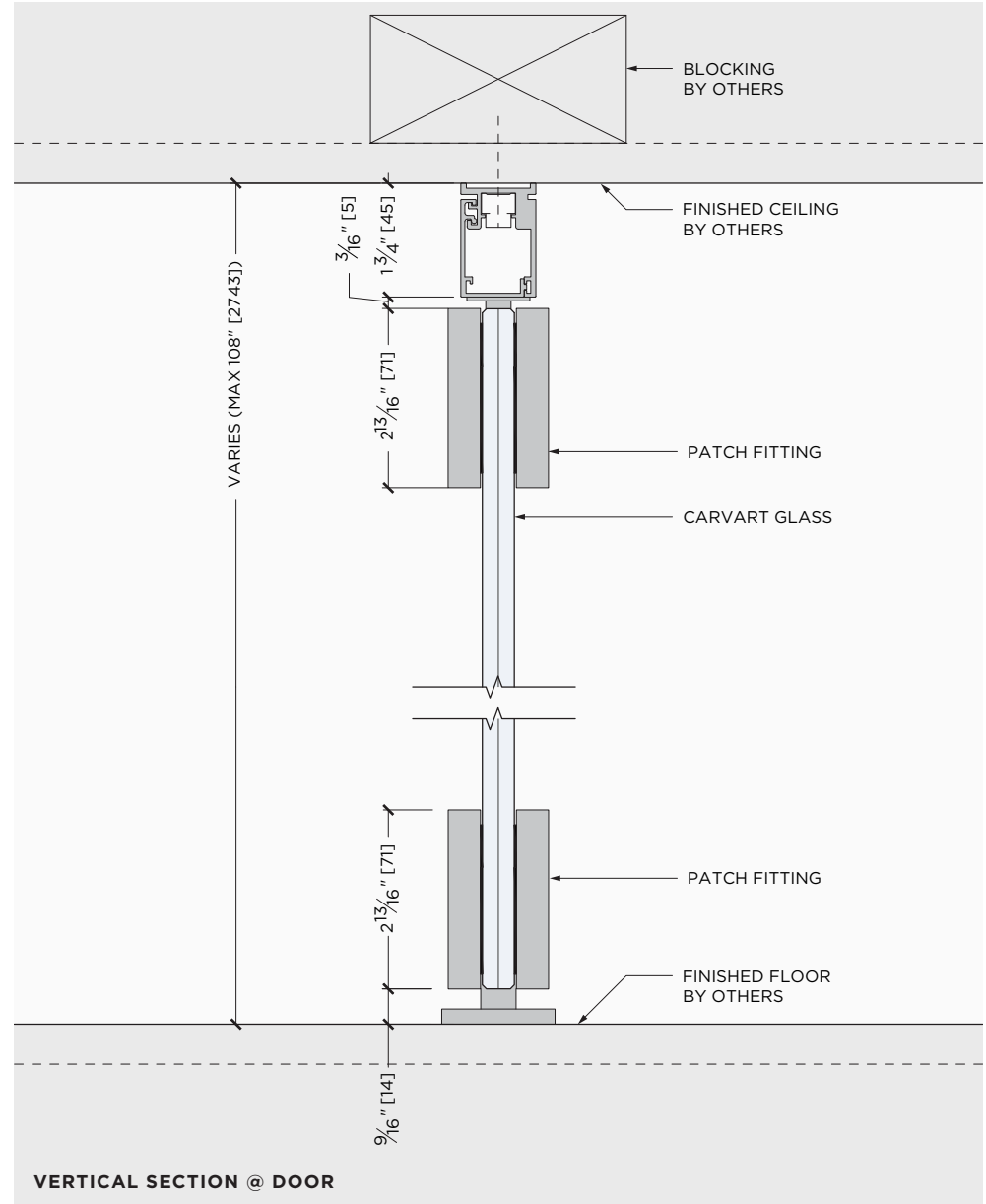
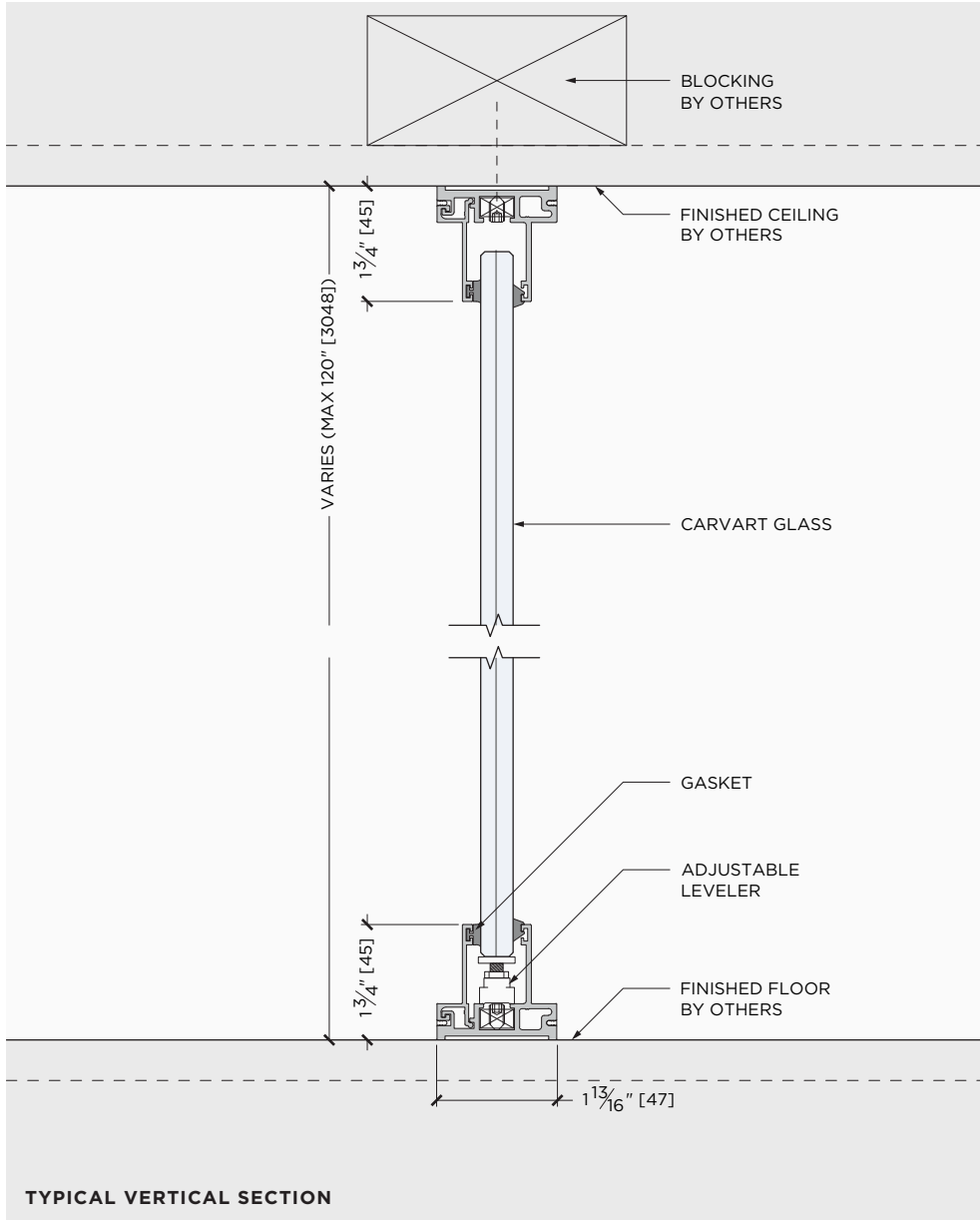

Simple > Frameless Pivot Door

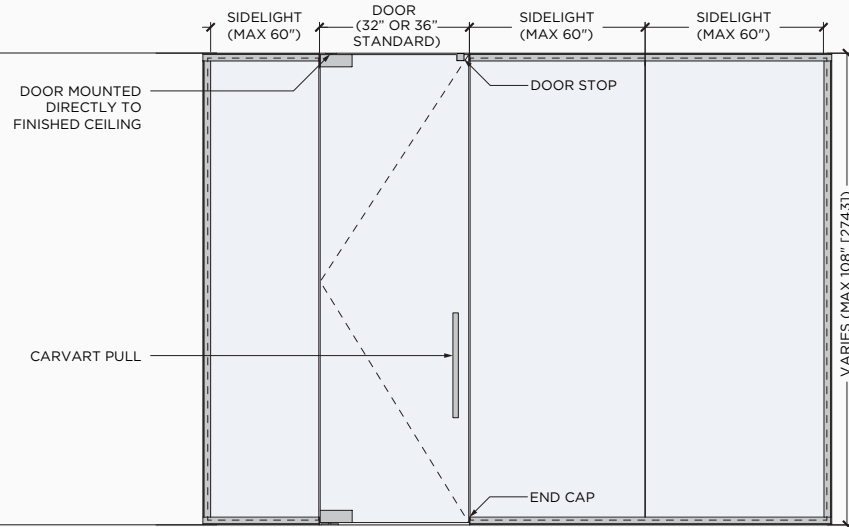

TYPICAL FRONT ELEVATION

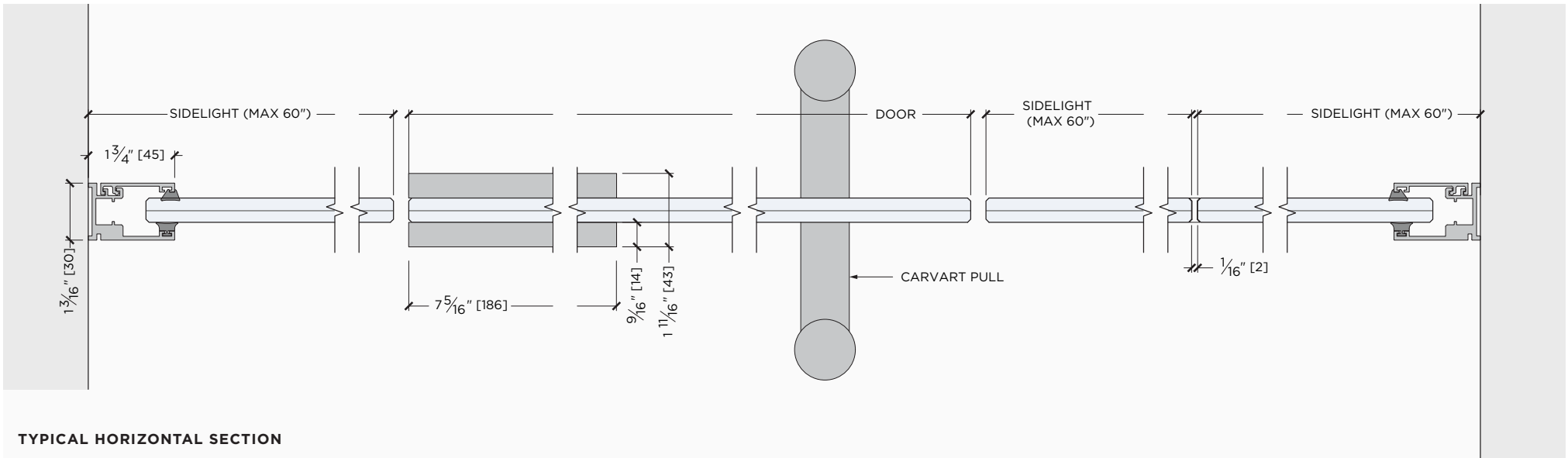

TYPICAL HORIZONTAL SECTION

Simple > Frameless Pivot Door

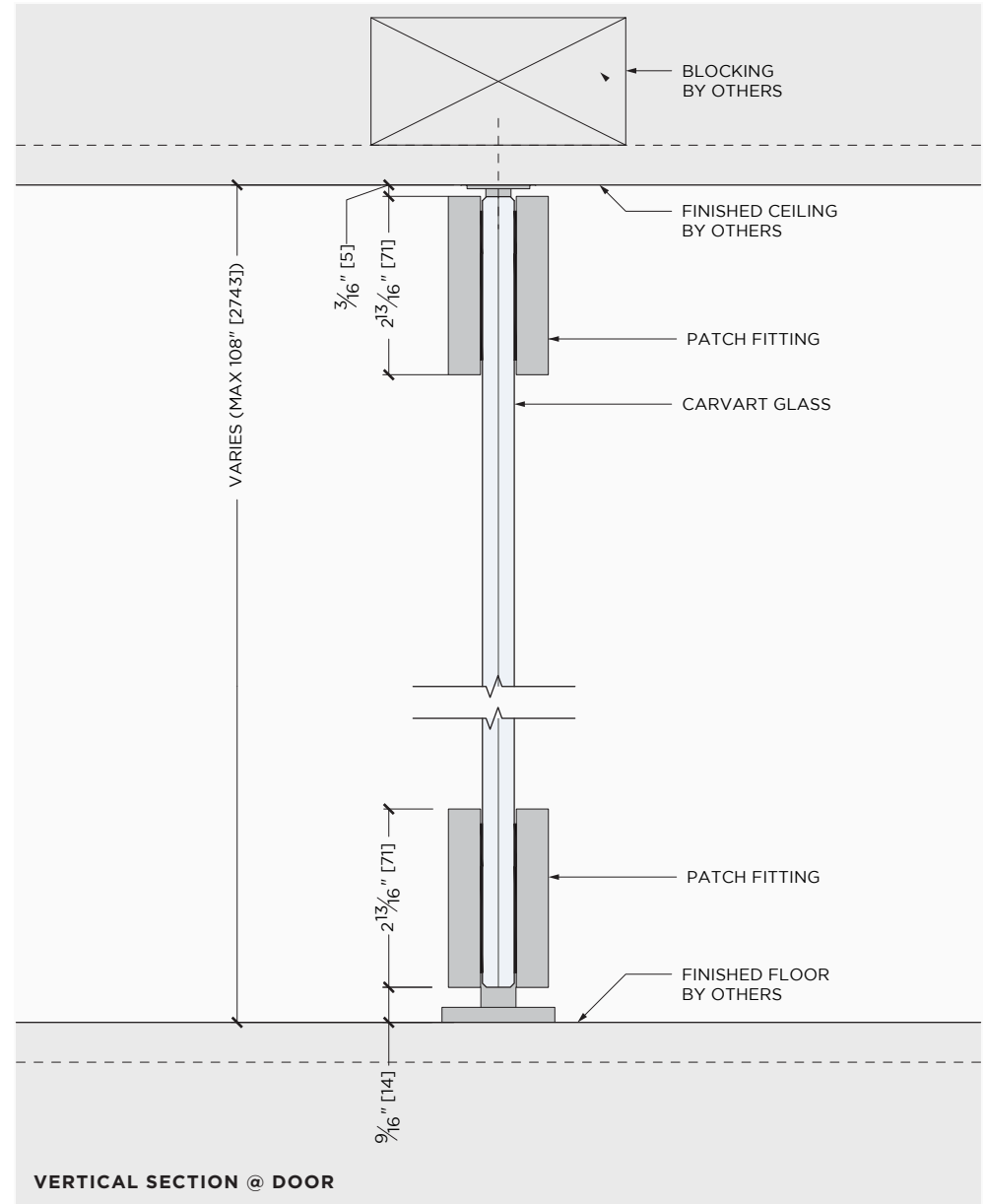
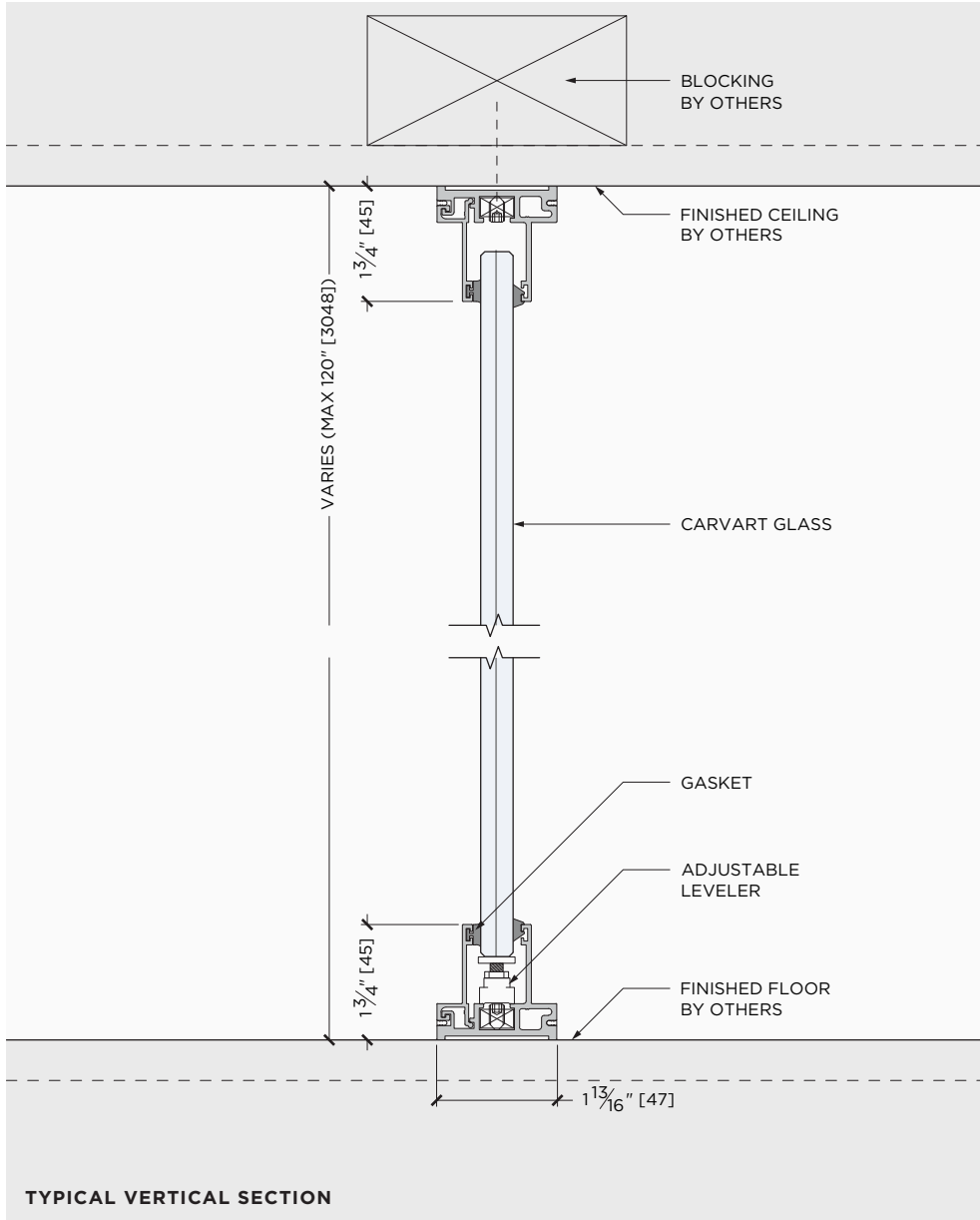

Simple > Framed Pivot Door

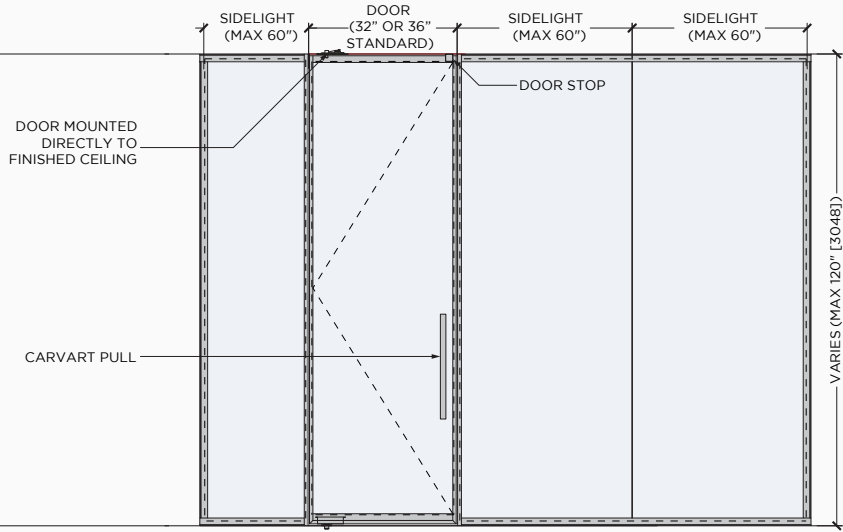

TYPICAL FRONT ELEVATION

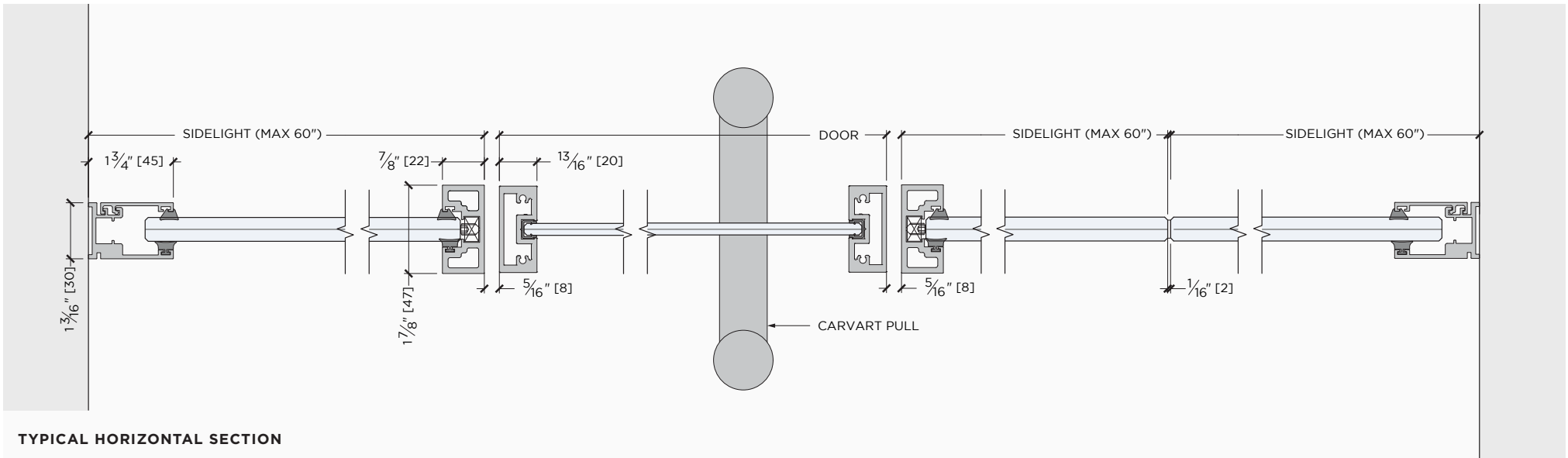

TYPICAL HORIZONTAL SECTION

Simple > Framed Pivot Door

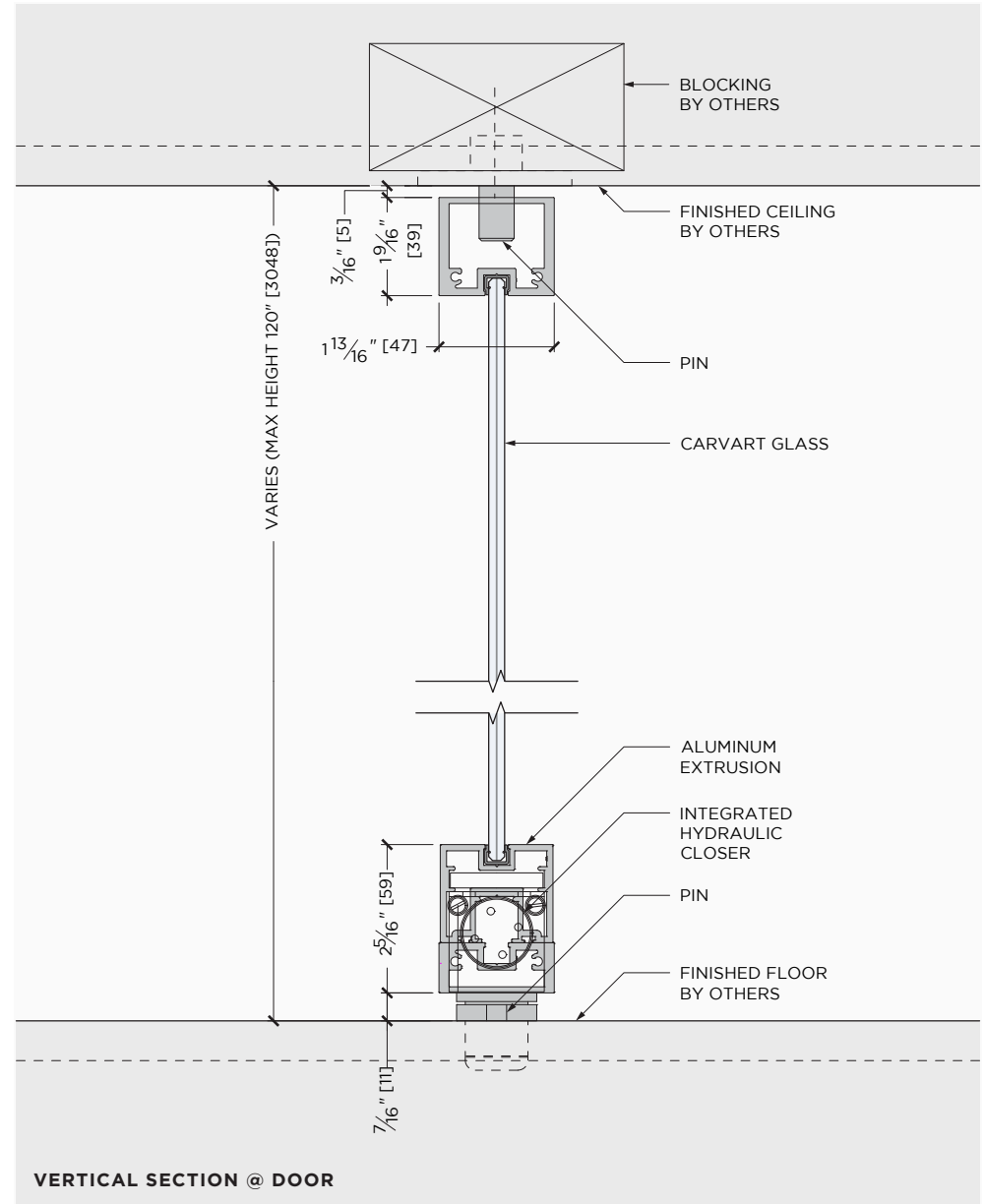
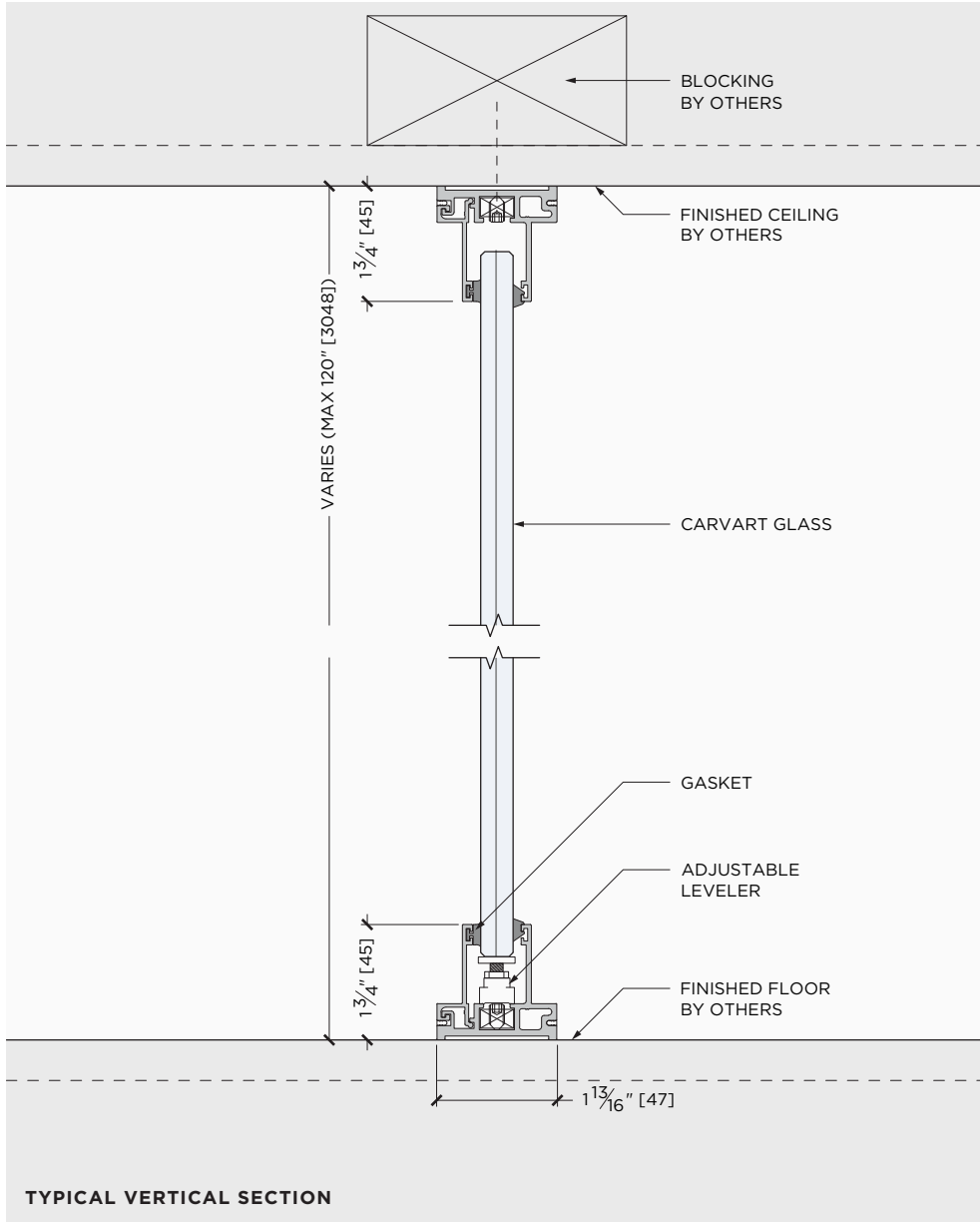

Simple > Framed Sliding Door

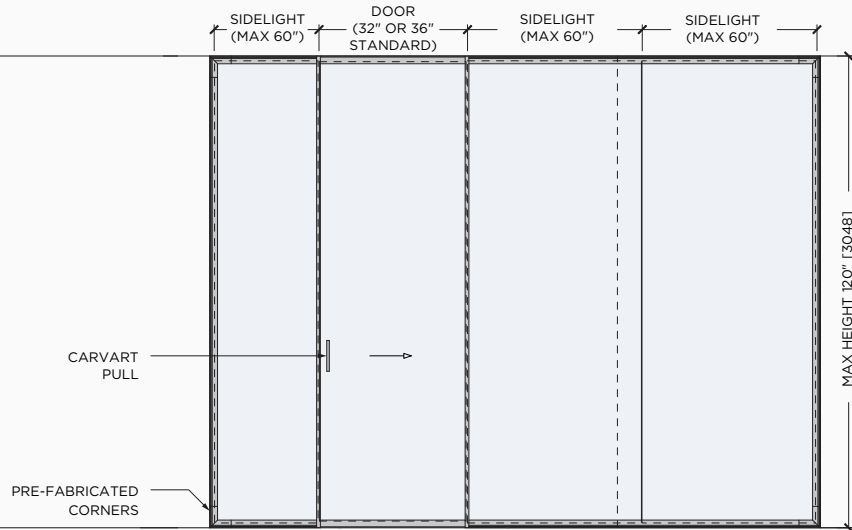

TYPICAL FRONT ELEVATION

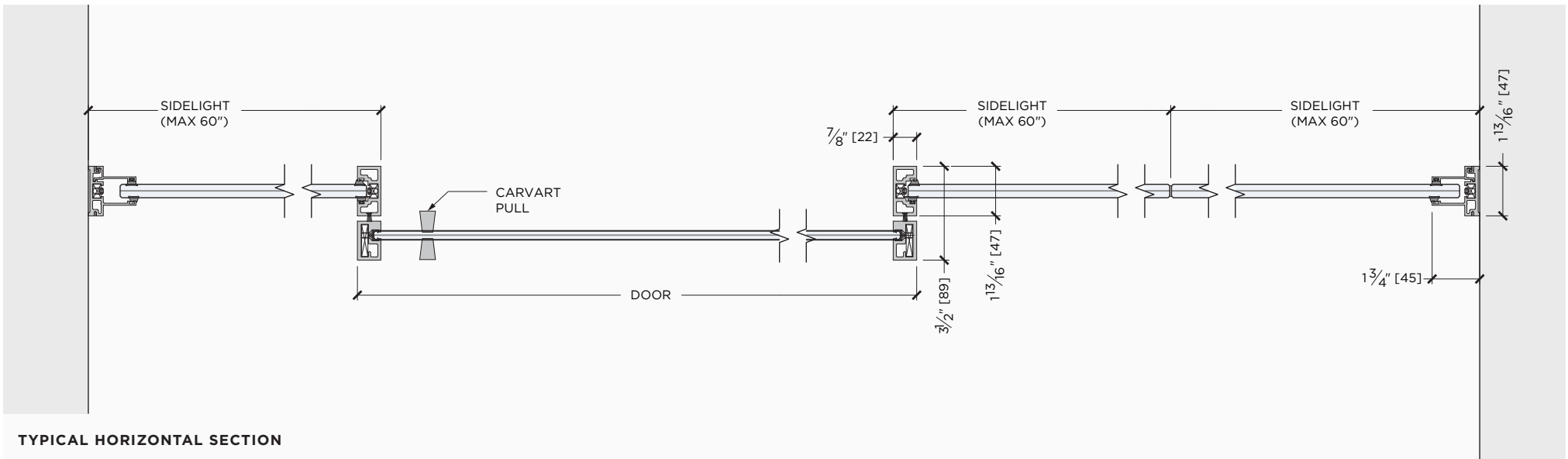

TYPICAL HORIZONTAL SECTION

Simple > Framed Sliding Door

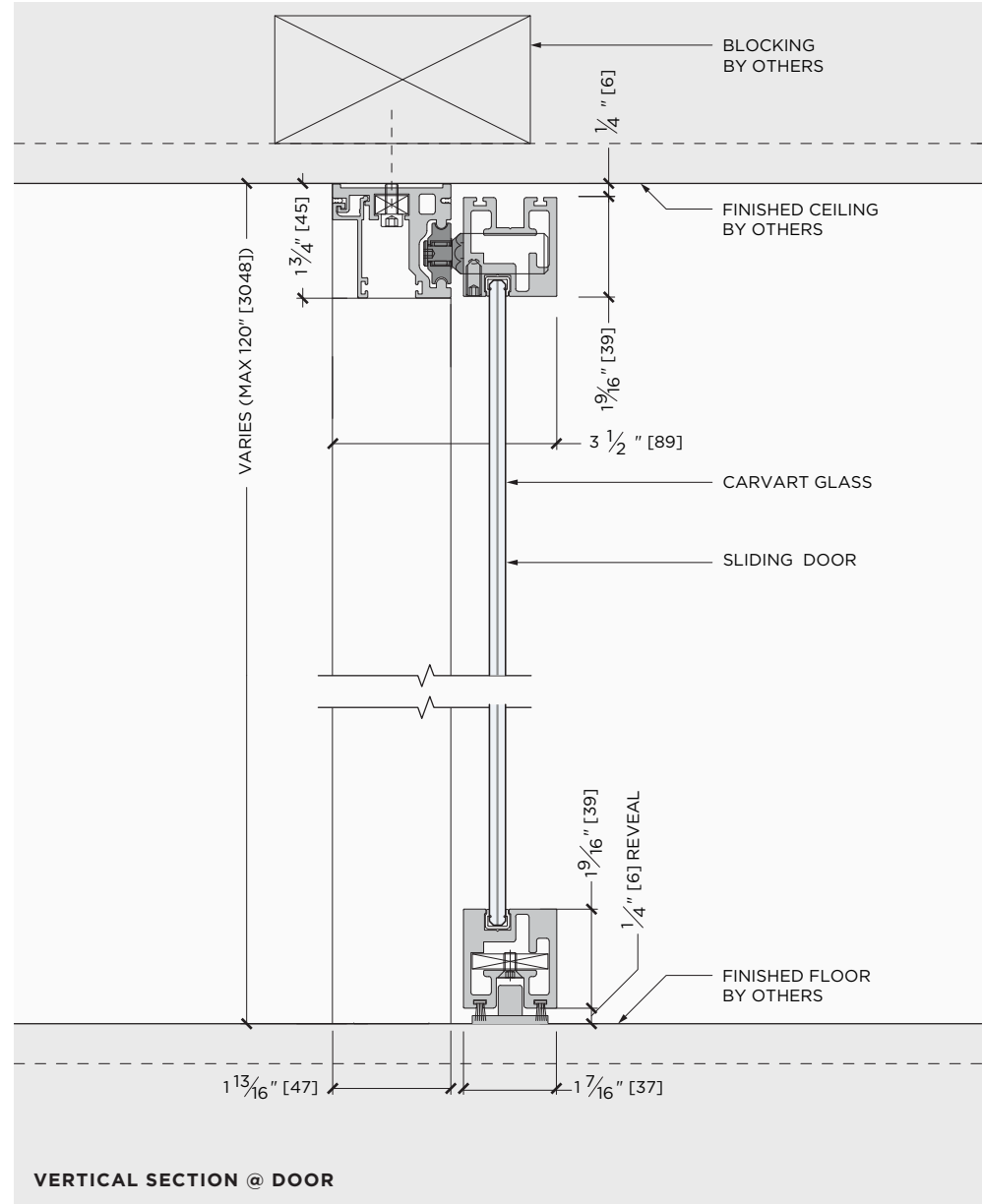
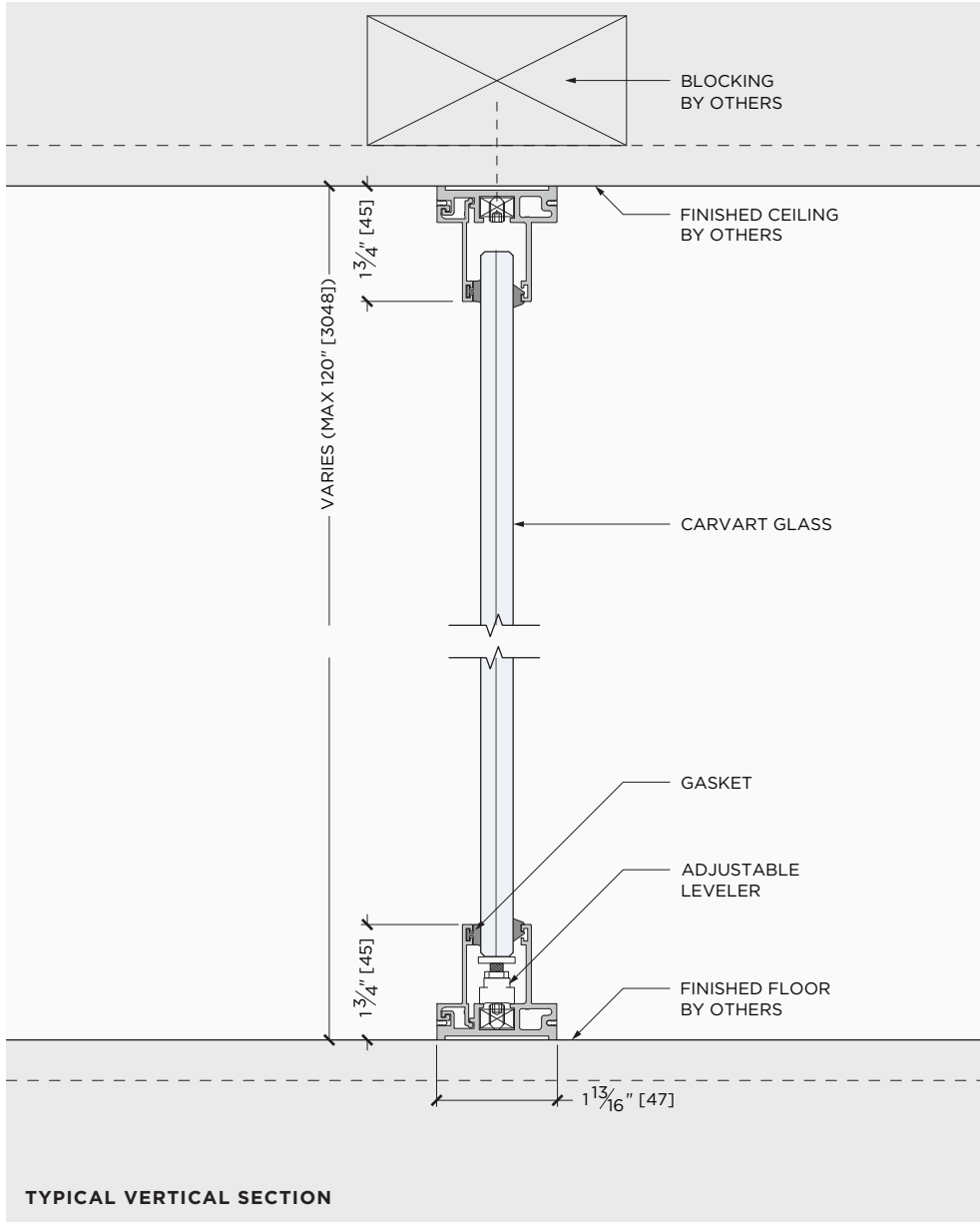

Simple > Frameless Sliding Door

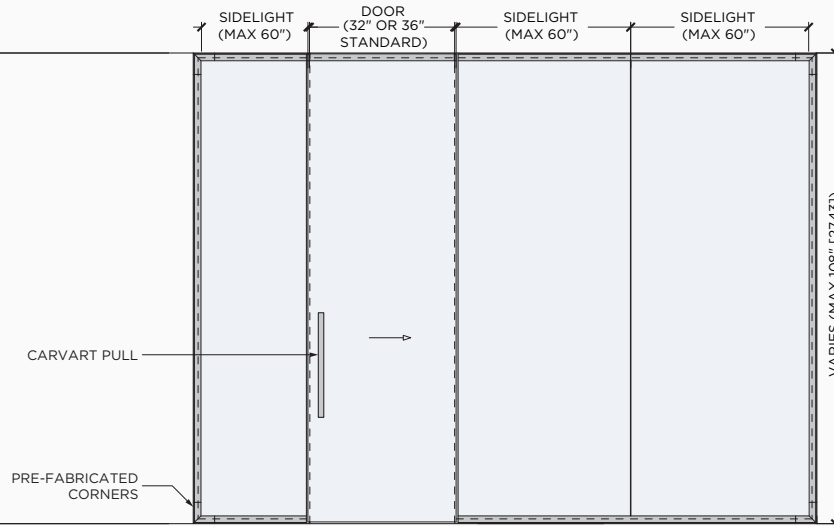

TYPICAL FRONT ELEVATION

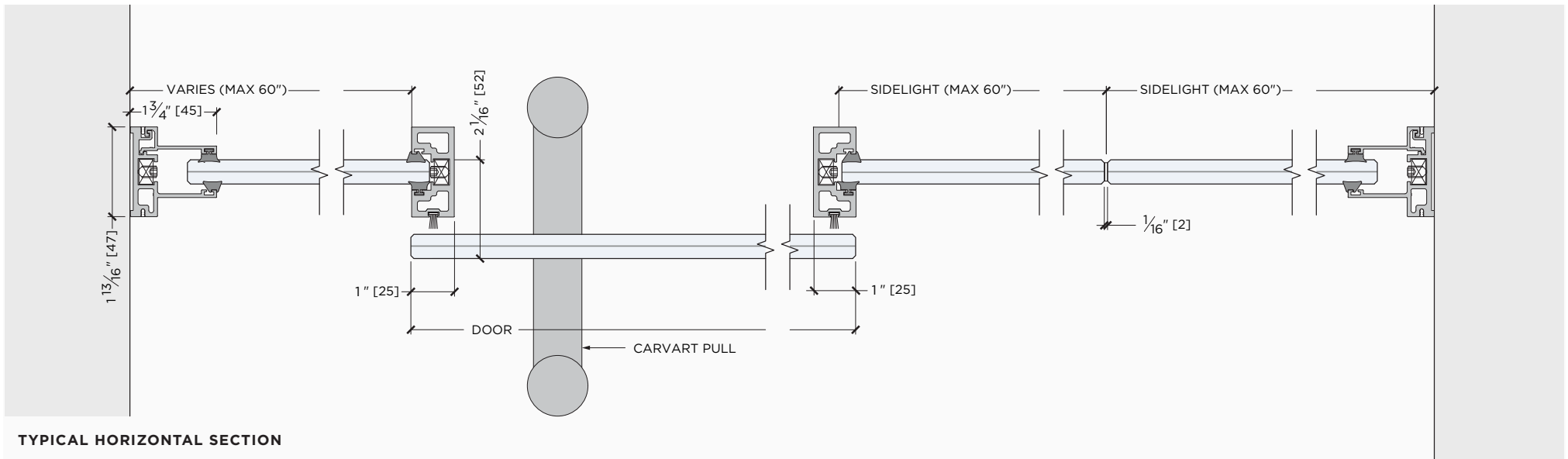

TYPICAL HORIZONTAL SECTION

Simple > Frameless Sliding Door

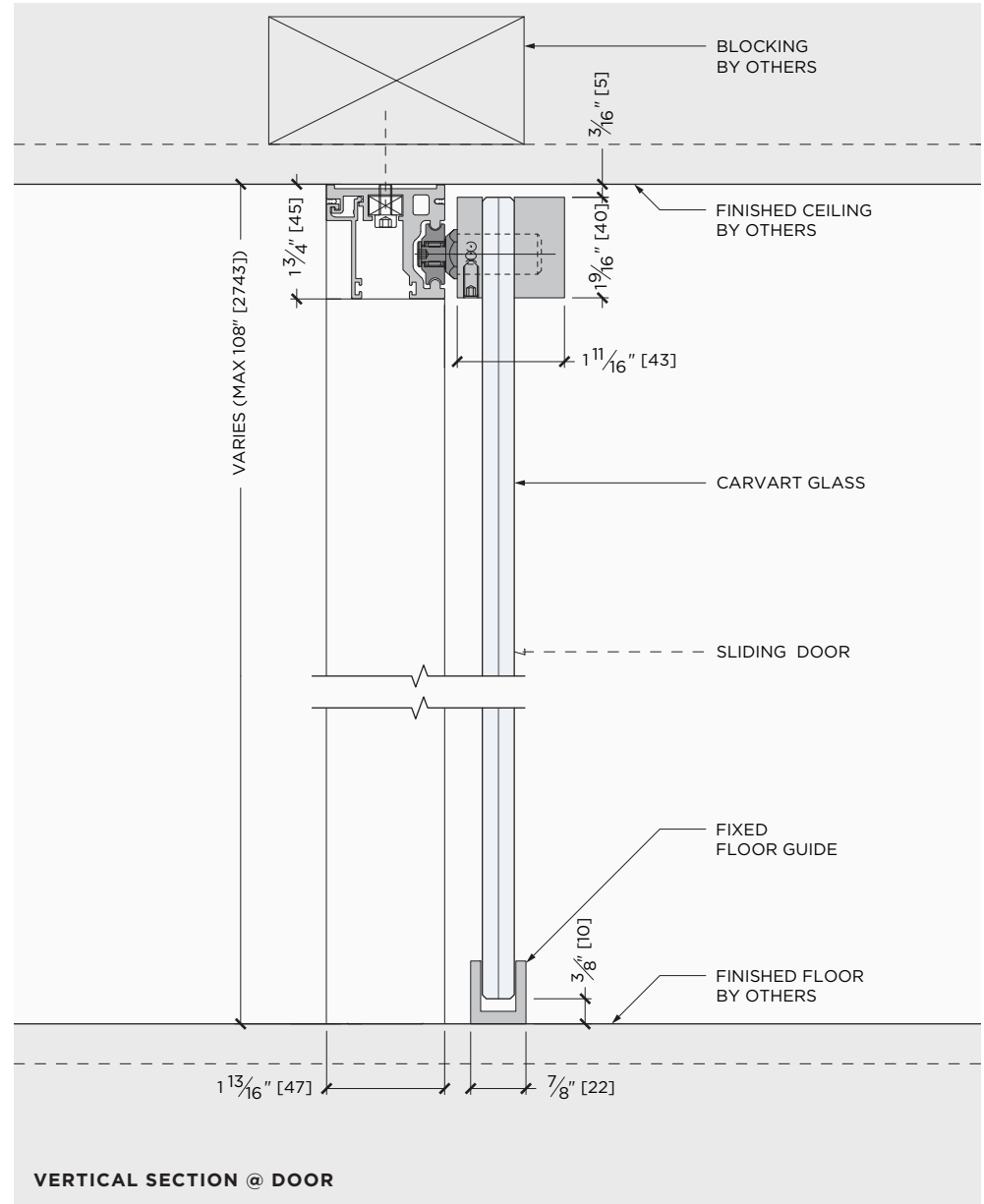
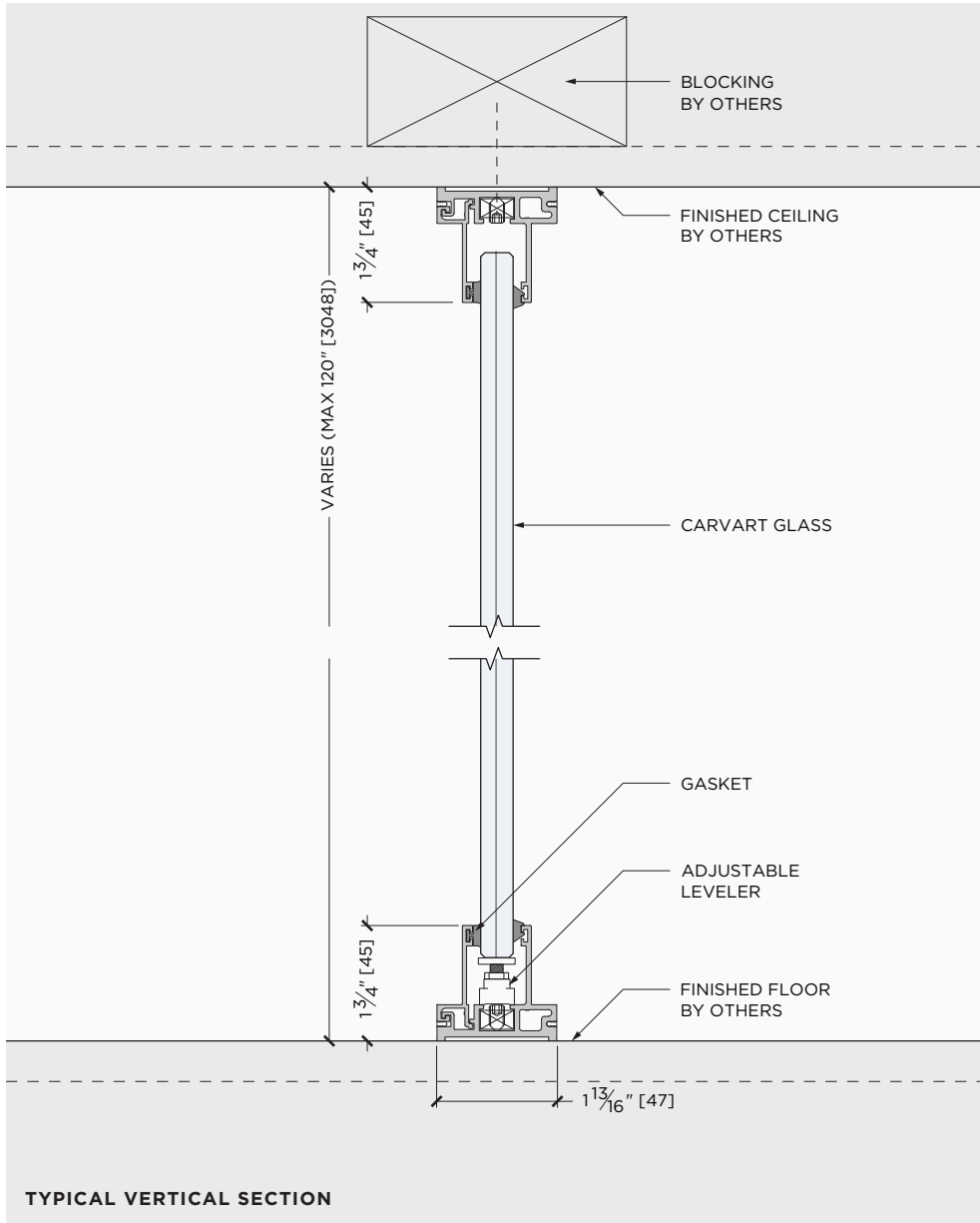

Options: Pulls and Closers

Ladder pulls available in:

- Multiple finishes (see chart)
- ADA configurations
- Locking/non-locking

LADDER PULLS



BACK-TO-BACK
NON-LOCKING

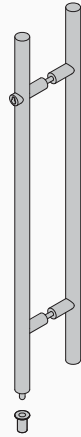

BACK-TO-BACK
LOCKING



24"
NON-LOCKING



36"
NON-LOCKING



48"
LOCKING OR
NON-LOCKING

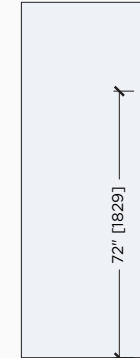

72"
LOCKING OR
NON-LOCKING

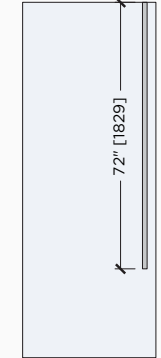

72"
CEILING
CONFIGURATION

PULLS & LEVERS

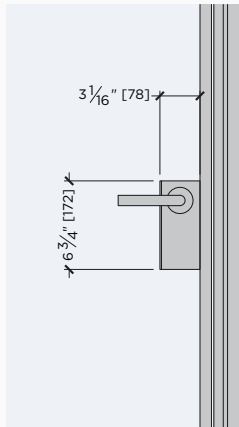

NON-LOCKING/
FIXED LEVER

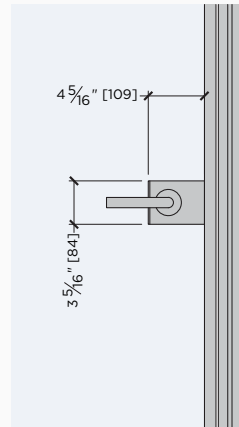

FIXED/DUMMY LEVER

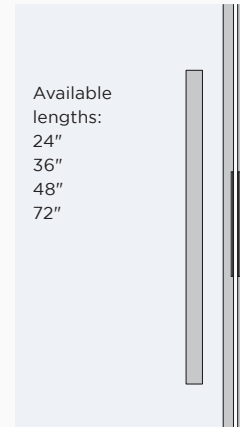

LATCH W/ LADDER PULL

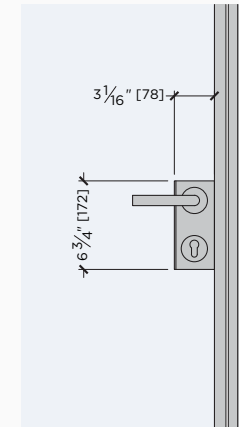

EURO LOCK
• Key/Thumb • Indicator/Thumb
• Key/Key • No Lock

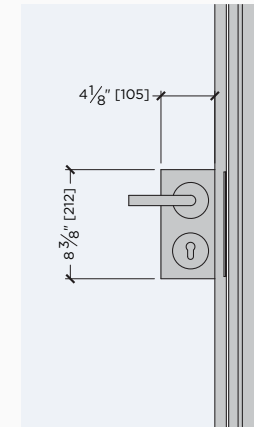

US LOCK/INTERCHANGEABLE
• Key/Thumb • Indicator/Thumb
• Key/Key • No Lock

Options: Simple > Door Connections

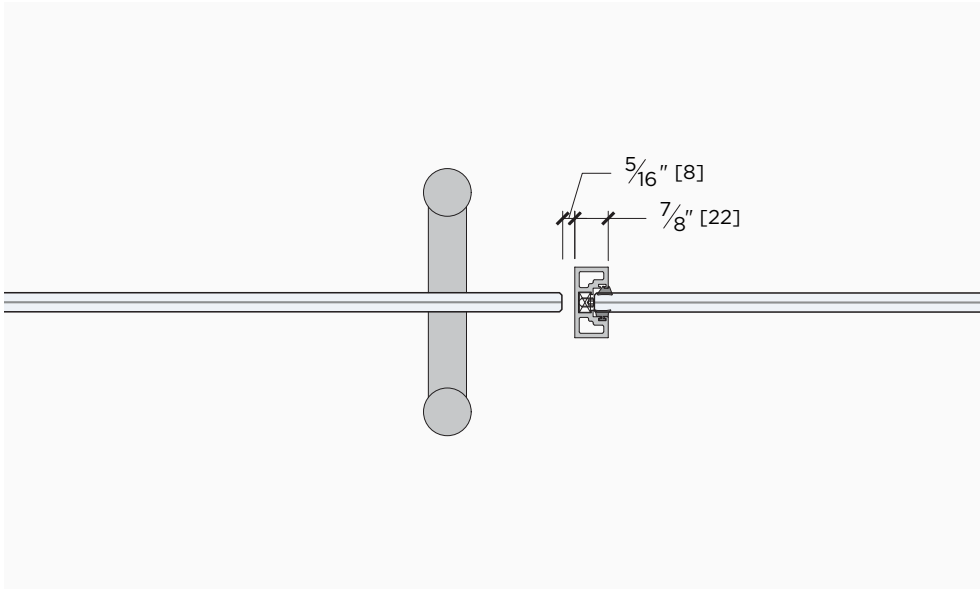

HORIZONTAL DETAIL FRAMELESS SWING

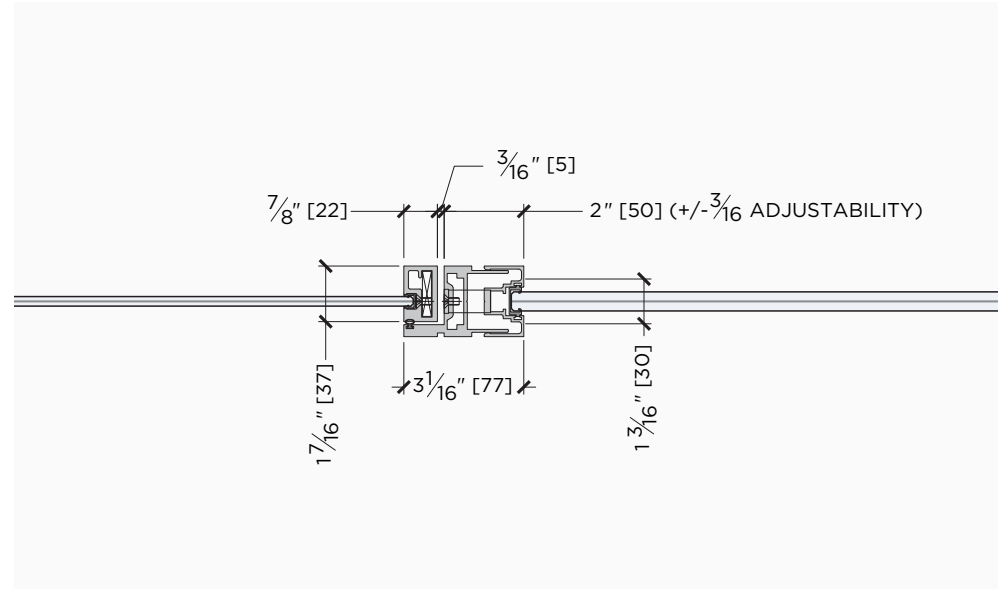

FRAMED HINGED JAMB DETAIL

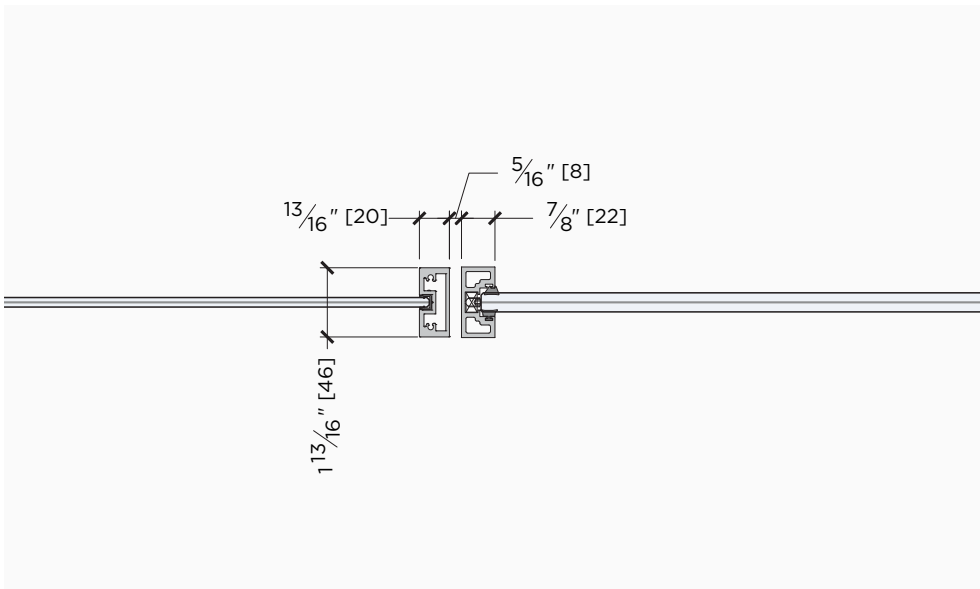

FRAMED PIVOT JAMB DETAIL

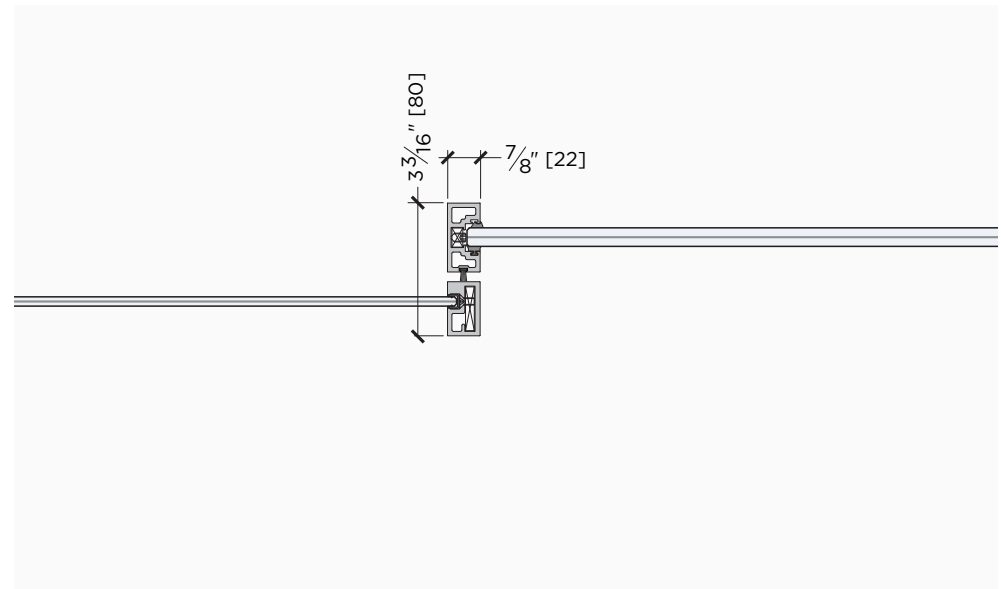

HORIZONTAL DETAIL FRAMED SLIDING W/INTEGRATED BRUSH

Options: Simple > Panel-to-Panel Connections

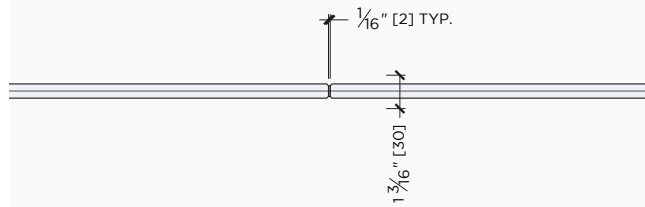

BUTT JOINT

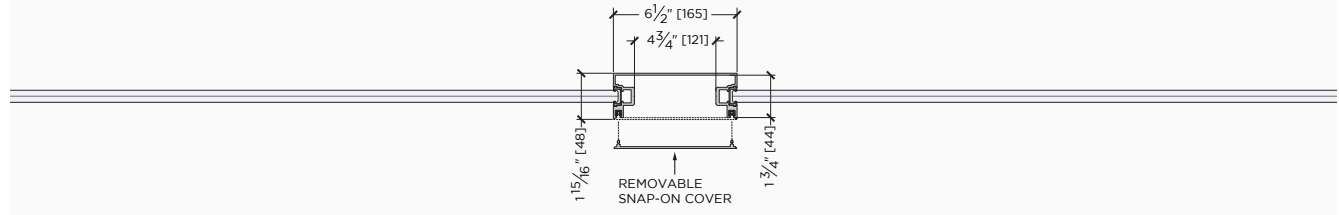

WIRE MANAGEMENT CHASE

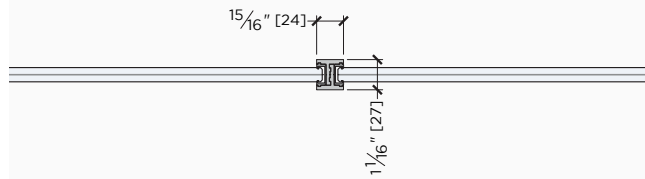

VERTICAL MULLION

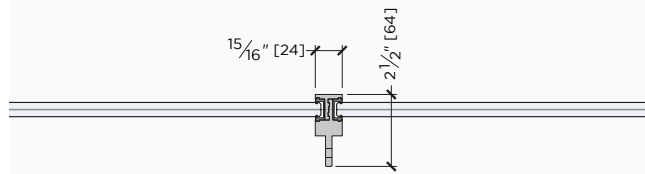

VERTICAL MULLION SHELF SINGLE SIDE

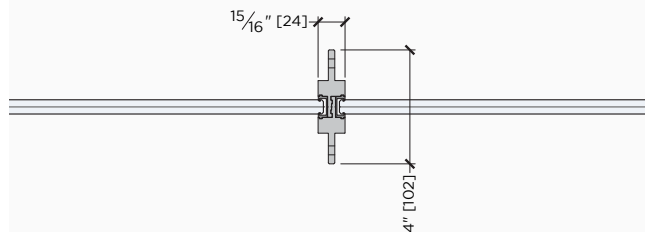

VERTICAL MULLION SHELF DOUBLE SIDE

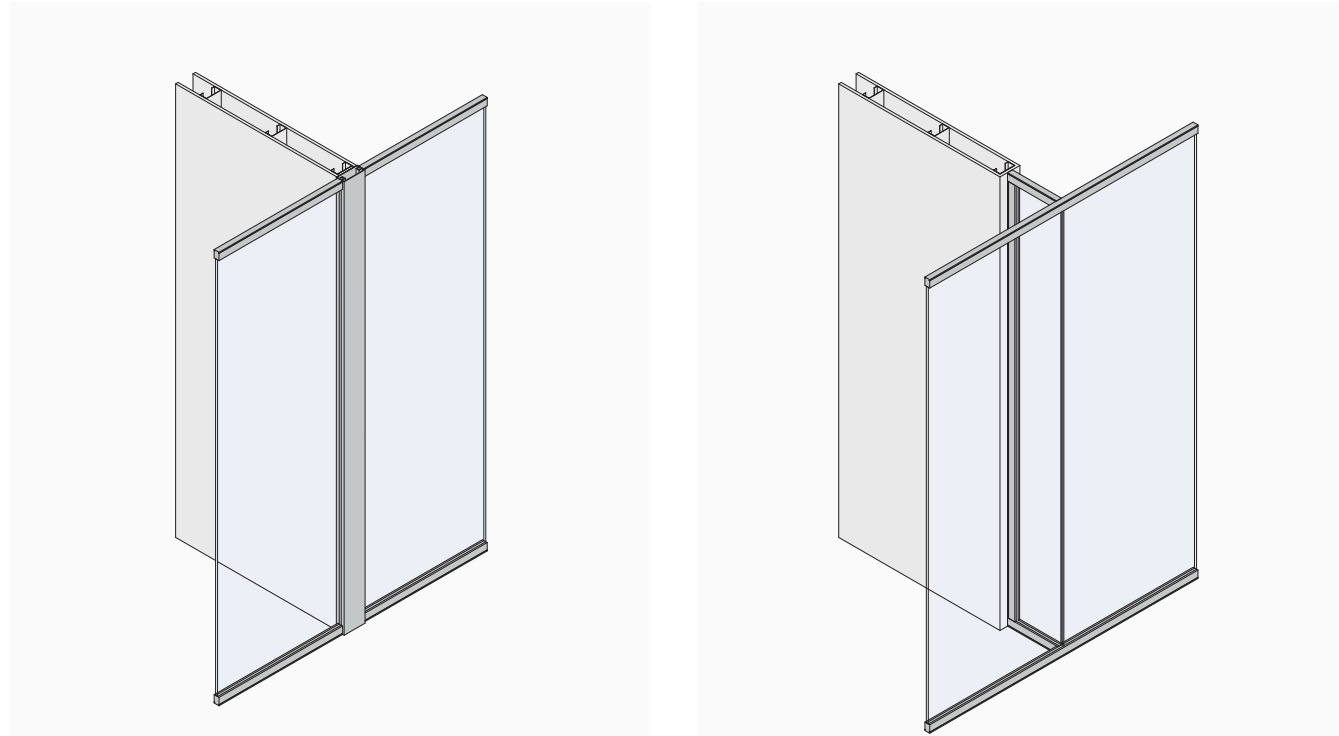

- Finish extrusion to match CARVART Slim or Simple extrusions
- Economic design alternative to cap the end of a partition between spaces and conceal cables/wires

PARTITION CAP ALTERNATIVE

- Typical glass return features a glass side lite that gives more light/transparency to adjacent spaces

GLASS RETURN @ PARTITION

Aesthetic options: Warehouse



SLIDING DOORS

SWING DOORS

Aesthetic options: Warehouse > Two alternatives for mullion frequency

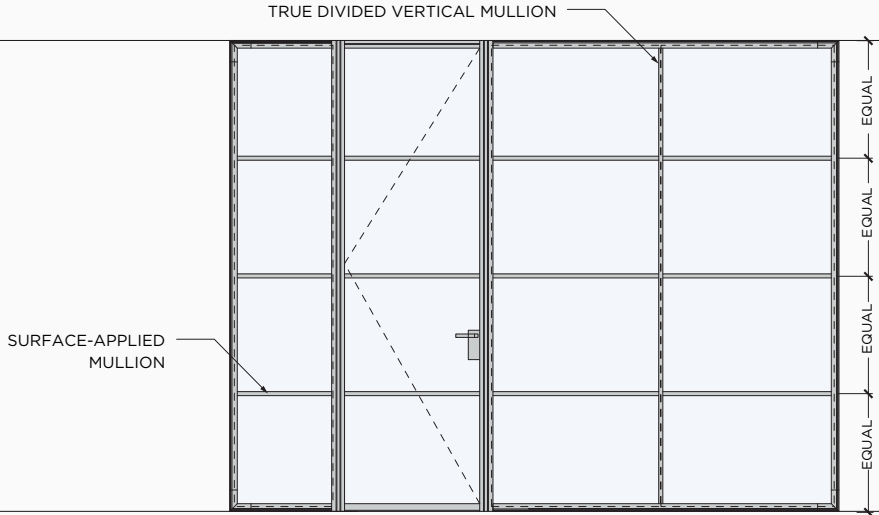

FOUR-DIVISION HORIZONTAL MULLIONS (W/ HINGED DOORS)

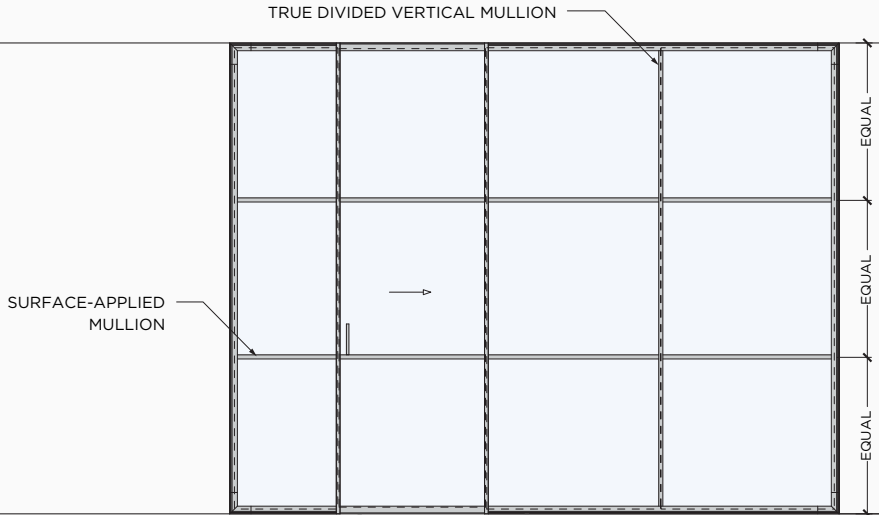

THREE-DIVISION HORIZONTAL MULLIONS (W/ SLIDING DOORS)

Warehouse

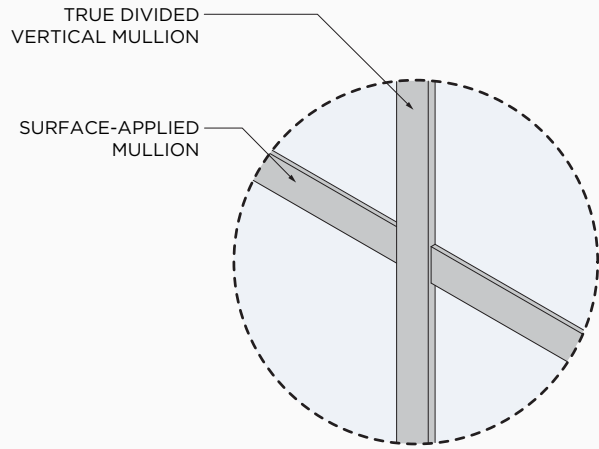

TYPICAL FRONT ELEVATION

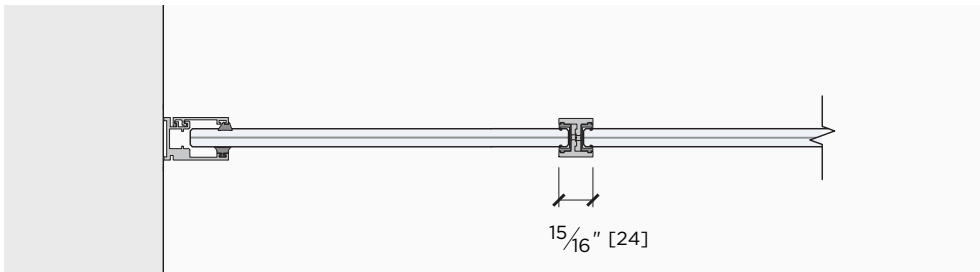

TRUE DIVIDING VERTICAL MULLION — SLIM

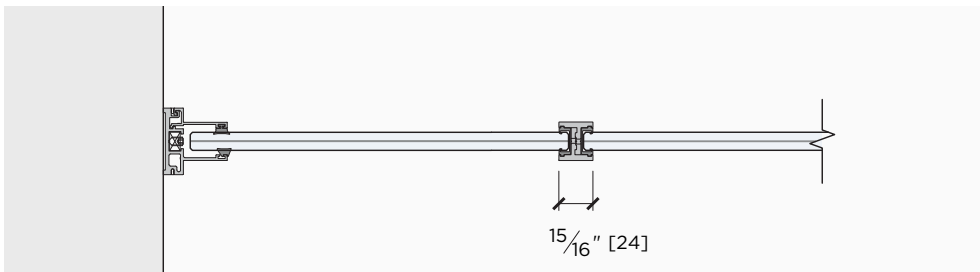

TRUE DIVIDING VERTICAL MULLION — SIMPLE

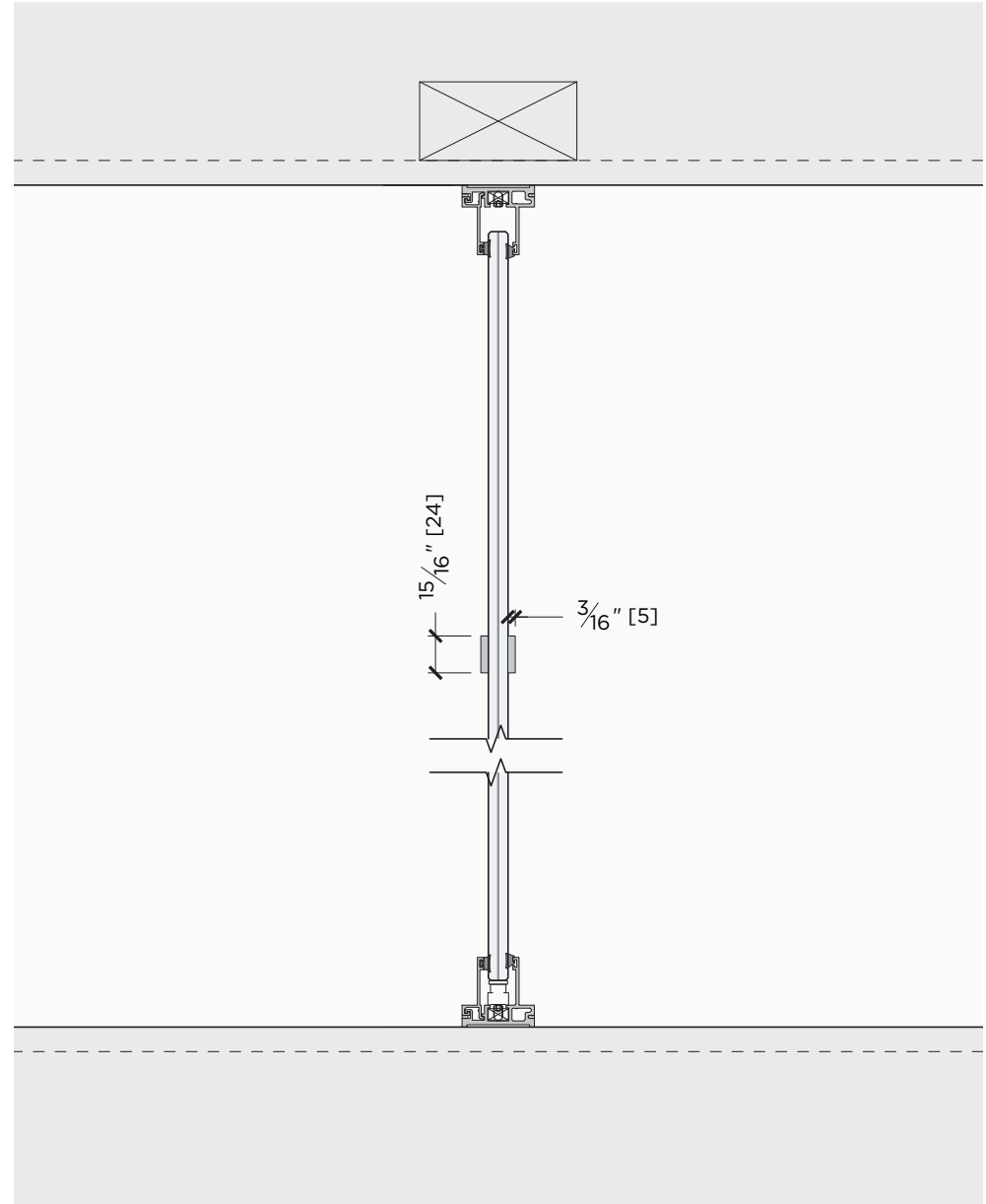

SURFACE-APPLIED HORIZONTAL MULLION

Accessories: glassPOST

Integrated mounting mullion to add accessories to Slim, Simple and Simple Double office fronts.

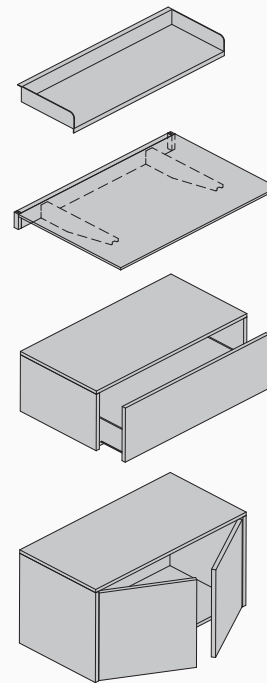
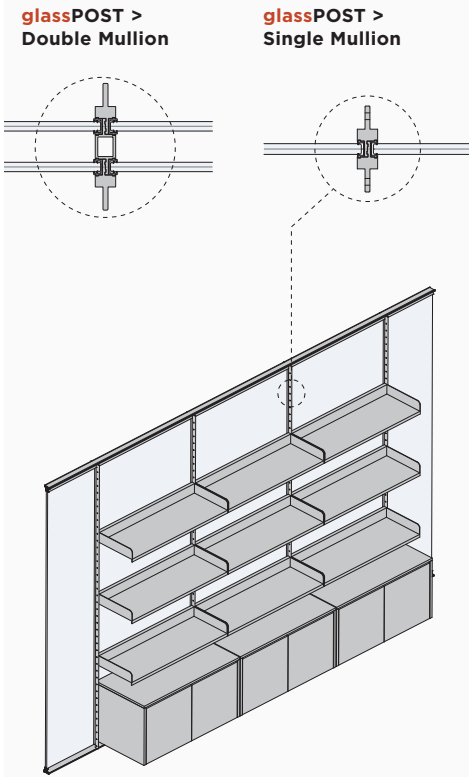

glassPOST INTEGRATION

glassPOST accessories can be seamlessly integrated with Slim, Simple and Simple Double office front partitions. By adding a mounting-mullion between the panes of glass, shelves, work surfaces, cabinets and drawers can be hung in front of the glass and integrated into any room design.

glassPOST ACCESSORIES

- Available accessories include:
- Standardized steel shelves at 35-7/16" wide
 - Brackets for customer-supplied work surface
 - Standardized drawers at 35-7/16" wide
 - Standardized cabinets at 35-7/16" wide



Design appeal and detailing

- Hardware system engineered to accommodate fully framed (4-sides) or top/bottom captured
- All finish profiles and hardware are specifically engineered to keep sight-lines and design aesthetic minimal
- Frameless look available in both swing and sliding doors
- Lightweight and optimized hardware solutions keep system efficient and easy to operate
- Create unique appearance with CARVART glass options

SLIM

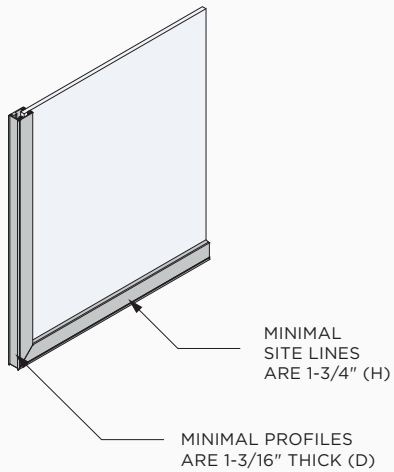

SIMPLE

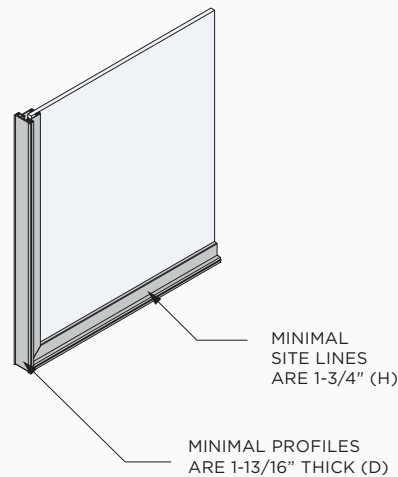

MINIMAL FRAMING

glassWALLS > Slim and glassWALLS > Simple are two glass partitioning systems that address every type of environment and are characterized by excellent quality and imaginative design in line with the most current architectural trends. Both lines offer an expanded and amplified ways for designers to use and outfit the wall system. Multiple combinations of doors, storage units, shelves, and hang-on accessories offer a broad range of function and flexibility. And the design is clean, modern and minimal in its appearance and application.

CONTEMPORARY FINISHES

CARVART glassWALLS are offered in a range of modern metal framing finishes that set new benchmarks to meet the prevailing urban retro feel in facility design. Those metal options combined with the vast array of CARVART Architectural Glass options present designers an endless way to instill a distinctive class, privacy and uniqueness in the workplace.

EXPANDED STYLING

A new interpretation in glassWALLS, CARVART Officefronts offer a fantastic system of partitions and doors in glass and aluminum, including “warehouse styling”. Adding vertical and horizontal H-aluminum profiles joints, synonymous to old style iron warehouse window frames; with this new design, it is possible to keep the high-level technical characteristics of a product, ease of installation, and high performance noise insulation levels.

Ease of installation

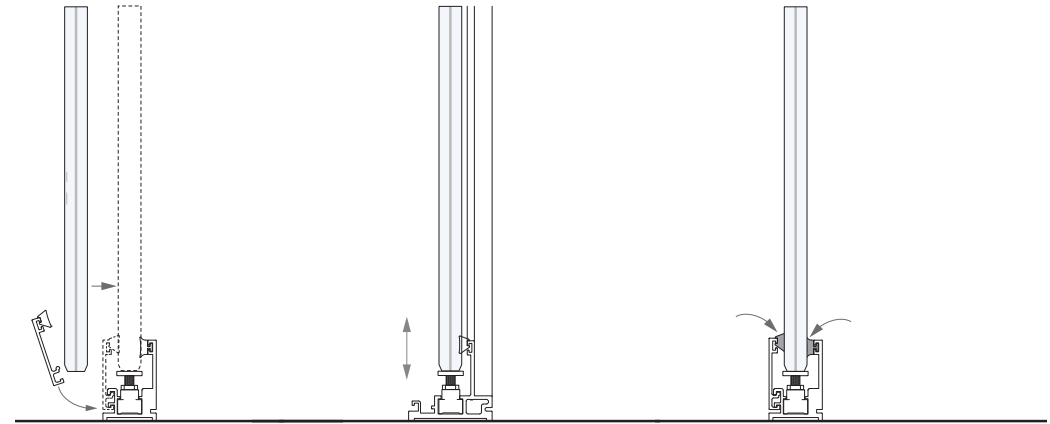
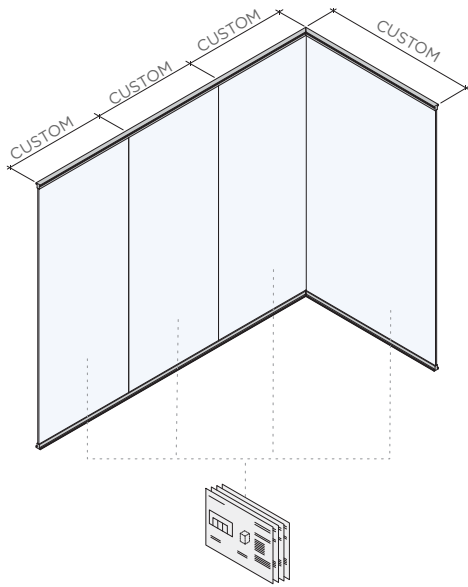

CUSTOMIZATION & COORDINATION

- Hardware and glass dimensions can be fully customized to fit any site condition and configuration
- Shop drawings are generated on a per project basis and identify and label all hardware and glass pieces for easy sequencing and installation

INNOVATIVE COMPONENTS

- Two-piece channel facilitates easy front loading rather than cumbersome up-down installation
- Adjustable levelers make glass leveling easy after glass is set to reduce trial and error leveling that drastically adds to labor time and costs
- Dry-glazed wedge vinyl goes in easy after two-piece channel is installed to secure glass and system

Life cycle maintenance

Due to the inherent design of the products and ease of installation and assembly, facility managers can anticipate lower labor and maintenance costs than most sliding door systems. Replacements are also made easy due to the dry-glazed assembly on most models and CARVART's digitally stored files can be

referenced from the shop drawings and re-ordered at any time. The hardware is tested and cycle tested at high-frequencies to ensure durability and over-engineered strength and quality. The minimal design ensures products are easy to clean due to sleek profiles and limited hardware.

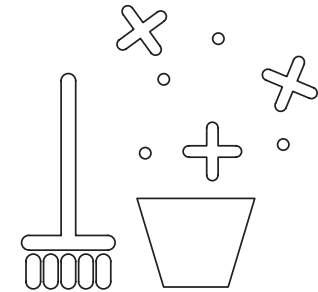
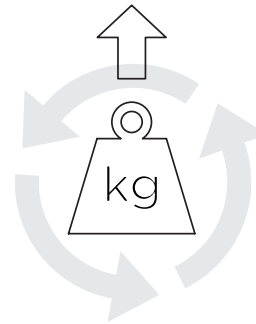
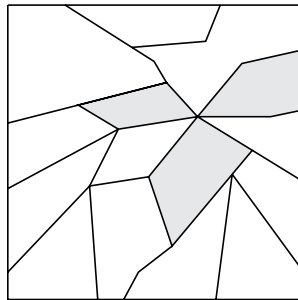
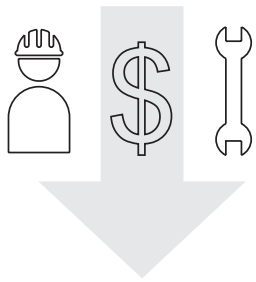

EASE OF INSTALLATION

CARVART glassWALLS offer a simple two-piece profile that mounts easily within a space and are designed to accept and position glass panels in an efficient and seamless manner. The modular design of the product make it well received by installation teams and allow for future reconfiguration, when required.

EASY TO REPLACE

Intermediate panels are easily replaceable due to the dry-glazed assembly and easy-to-remove wedge vinyl.

HIGH-CYCLE TESTED DURABILITY

All CARVART Officefronts are cycled-tested to hundreds of thousands of cycles and rated for weights far beyond the maximum panel size.

CLEANING AND MAINTENANCE

Virtually no maintenance outside of cleaning once the system is in place and installed. Profiles have minimum reveals and crevices to collect dirt and grime.

Project management coordination

- Coordination of custom glass and hardware machining (shape-cut glass pieces)
- Project management services and training for duration of project
- Years of experience handling numerous high-profile, complex office projects

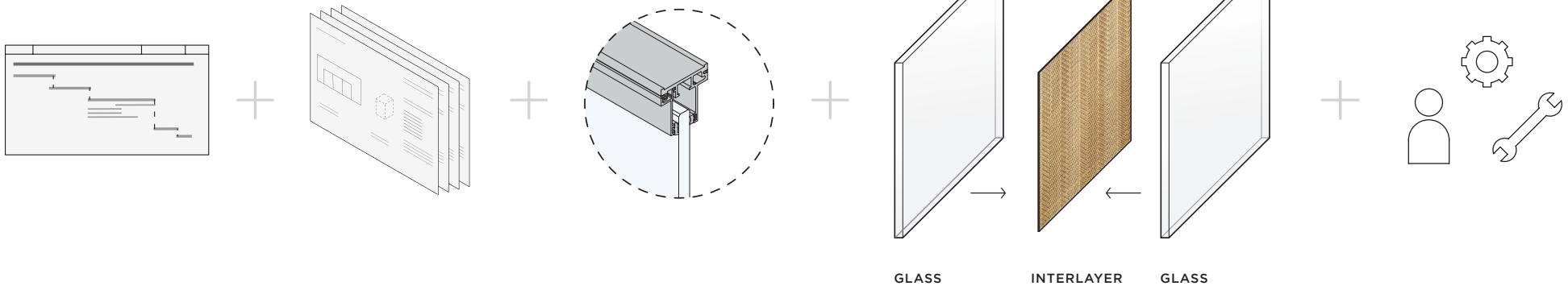

COORDINATION AND SHOP DRAWINGS

CARVART offers full project management and shop drawing services that are customized to each project. Coordination and project manager expertise ensure each project is delivered on time with specifically engineered shops drawings to facilitate trade and construction coordination.

HARDWARE

CARVART has a comprehensive selection of hardware options that can be specified to fit any design and architectural need.

GLASS DESIGN AND DEVELOPMENT

Work with a CARVART designer to customize glass design and selection to accommodate essentially any project need and desire. Glass can be customized and sized to fit each project's field conditions. CARVART offers a full range of glass options to meet almost any design, structural or performance challenge.

WARRANTY AND POST-DELIVERY SERVICES

After the delivery of CARVART products to the site, the full range of services don't end! CARVART prides itself on providing comprehensive services to facilitate project management, installation, facility maintenance, training and product replacement.

Product performance

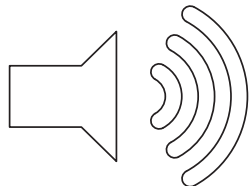

ACOUSTIC PERFORMANCE

The design and assembly of the glassWALLS > Slim and glassWALLS > Simple are inherently high-performing in sound isolation. There are a multitude of joints, gaskets and other sealing details that can be substituted throughout the system to improve acoustics or modify aesthetics. CARVART's laminated Architectural Glass line can be added to further improve sound performance. With a fully framed system and sound isolating details, users can expect increased sound dampening in both systems and when the glassWALLS > Simple Frame is selected, the system essentially creates full acoustic privacy.

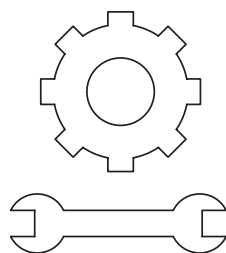

PRE-FABRICATION AND CUSTOMIZATION

All CARVART's products are engineered to facilitate ergonomic and efficient installation. Labor overages often drive up the cost of an installation. In response to this, CARVART has developed all the glassWALL systems to include self-leveling components that can be adjusted *after* the glass is installed, a fully dry-glazed system that allows for easy installation and replacement and pre-fabricated components like mitered corners that not only ensure quality but also speed up installation.



ADA COMPLIANT

CARVART glassWALL systems offer a range of opening types that can be customized to accommodate clear widths that meet and exceed accessibility needs. Door components like pulls and closers that meet grip and opening force requirements are also available with certain door types and configurations. Pull heights and configurations can also be modified and raised off the floor to accommodate ADA codes.

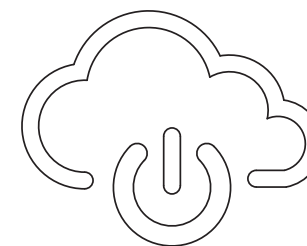

DATA AND POWER INTEGRATION

All systems can incorporate cable management components and extrusions that enable doors and glassWALL systems to be fully wired and conceal digital infrastructure.

Overview

CURATED HARDWARE FINISHES









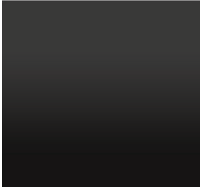

CARVART's team and resources bring an innovative spirit and celebrates the creative process. Our strength is solving design challenges with sophisticated detailing, engineering and a cohesive blend of materials and hardware finishes across CARVART's minimalist interior and exterior architectural products and systems.

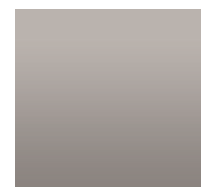
CARVART empowers the creative process by curating hardware system finishes from natural anodized aluminum with polish, satin, brushed, antiqued, blackened and other elegant techniques as well as the option to select any RAL color for powder coating.

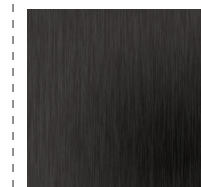
GUIDELINES

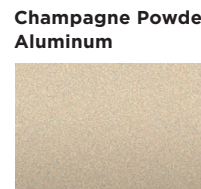
- Hardware finishes appropriate for each system may vary in color, type and other properties.
- Explore finish options below and consult with a CARVART team member for custom capabilities.

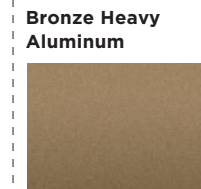
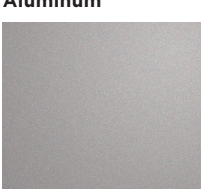
visit carvart.com/materials

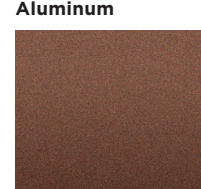
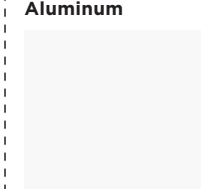
<p>Black Powder Coat Aluminum</p> 	<p>Midnight Powder Coat Aluminum</p> 	<p>Warm Grey Powder Coat Aluminum</p> 	<p>Satin Anodized Aluminum</p> 	<p>Blackened Aluminum</p> 
<p>White Powder Coat Aluminum</p> 	<p>Charcoal Powder Coat Aluminum</p> 	<p>Champagne Powder Coat Aluminum</p> 	<p>Brushed "Stinless" Aluminum</p> 	<p>Bronze Heavy Aluminum</p> 
<p>Metallic Silver Powder Coat Aluminum</p> 	<p>Light Grey Powder Coat Aluminum</p> 	<p>Terra Cotta Powder Coat Aluminum</p> 	<p>Polished Aluminum</p> 	

Overview

CURATED MATERIALS

CARVART's team and resources bring an innovative spirit and celebrates the creative process. Our strength is solving design challenges with sophisticated detailing, engineering and a cohesive blend of materials across CARVART's minimalist interior and exterior architectural products and hardware systems.

CARVART empowers the creative process by curating an inspiring material offering of glass, stone, wood, CHPL, metals, meshes, textiles and more with patterns, textures, finishes and levels of transparency and reflectivity that allows creators to accurately envision their design.

GUIDELINES

- Materials appropriate for each system vary in size, thickness, type, weight and other associated properties.
- Explore each material for inspiration at carvart.com/materials and see full material palettes.
- Due to the various ways of creating with these materials, please consult a CARVART team member to ensure your material is best suited for a specific architectural product application.
- Materials can be integrated into CARVART's architectural system or available in sheets.

visit carvart.com/materials

GLASS



Color
Translucency & Reflectivity
Interlayer
Pattern & Texture
CARVART Digital Experience

CHPL



Color
Woodgrain
Rock
Metal
Polaris

STONE

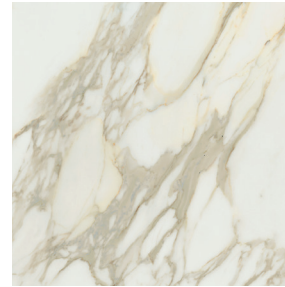

Porcelain

WOOD



Natural Veneer
Reconstituted Veneer
Perforation Patterns

METAL

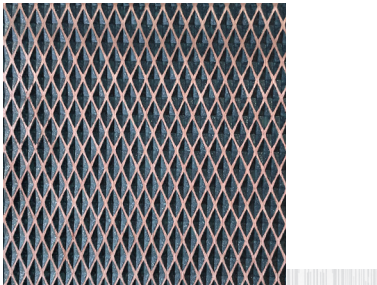

Copper
Plated
Powder Coated

08 Glisten

MESH

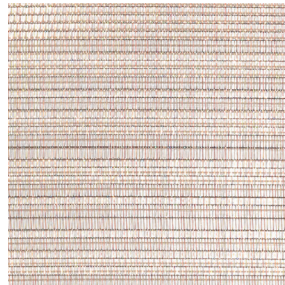

Glass Interlayer
Wire Mesh

TEXTILE



Acoustical
COM

WALL COVERING

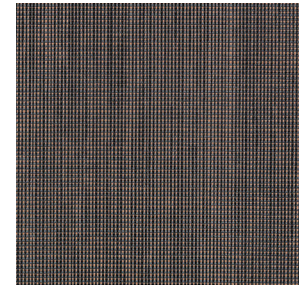

Acoustical
COM

CARVART®